

Applications

LIGNO® Acoustic light timber acoustic elements **for acoustically effective panelling** are used in industrial buildings (e.g. offices, indoor swimming pools, sports halls) as well as in residential buildings.

- suspended ceilings – for example under wood and concrete structures.
- wall coverings – also in front of masonry or concrete
- acoustic canopies – with edge profiles and light fixtures as acoustic sails freely suspended in the room.
- grid ceiling – as cut-to-size panels for insertion into standard system ceilings.

Structure / technical data

The cross laminated timber acoustic panels consist of three layers: Factory slitting of the first layer brings about a batten look on the visible face. The panelling is **ball-impact proof**, appropriate assembly provided. The middle ply (transverse layer) is oriented at right angles to the top layer thus providing for a high degree of dimensional stability. The backside layer in turn is formed by at least four panels running lengthwise.

Acoustic absorbers are integrated in the transverse layer. Thanks to the recessed absorber material, the panel is **ideal for renovation work** because the absorption effect will not get lost through painting or grinding down. **Surface structuring** achieves additional acoustically advantageous diffuse sound scattering.

- Coverage width: 625 mm
- Type of wood: Spruce / fir (wood moisture content: $9 \pm 2\%$)
- Gluing: PUR adhesive (formaldehyde free), adhesive by weight approx. 1.1 % (triple layer)
- Building material class (DIN 4102): B2 / Special versions in fire classes to B-s1-d0 according to EN.
- Places of installation: **Structures closed on all sides and heated**, as well as **covered, open structures**, elements **not exposed to the weather** (use class 0 according to DIN 68800 / service classes 1 and 2 according to Eurocode 5 for wood moisture $< 20\%$, diagram for equilibrium wood moisture see page 18).
- LIGNO® Acoustic: natureplus®-certificate no 0211-0606-014-1,
standard absorber from wood fibre: natureplus® certificate no 0104-0710-012-4

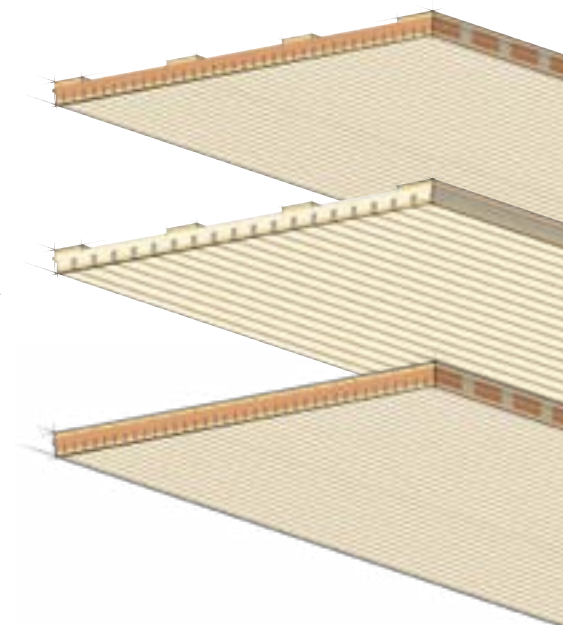

Contents

Applications and suitable element types.....	2
Green building	3
Element configuration and designation	4
Type 3S_33.....	6
Type 3G_33.....	7
Type 3S_39 (specifically for 3D profile).....	7
Surface (wood types)	8
Flame retardancy.....	9
Final treatment	10
Substructures.....	11
Acoustic profile.....	12
Installation on wood substructure	13
Installation on metal substructure	16
Installation in extraordinary locations, other substructures.....	18
Edging	19
Inspection openings	20
LED light strip.....	21
Grid ceilings, acoustic canopies, impact walls	23
Acoustic absorption properties.....	24
Element weight.....	30
Checklist material and tools.....	31
Processing guidelines	32



Application range and suitable element types

Application

Ceiling panelling / element installation in the stretching bond

Use of elements in standard length 2940 mm

Notes:

- Frontal butts are identifiable on the surface.
- Little offcut: The section of the last element is being used as the first element in the next row each time.



Element selection:

- Standard (flammability) 3S_33, 3S_39 ▶ page 6
- Fire retardant special configuration with
 - _C-s2-d0 3S_33
 - _B-s2-d0 3G_33
 - _B-s1-d0 3S_40
 ▶ page 9
to DIN EN 13501-1

Application

Ceiling canopy

LIGNO® Acoustic light can be used as ready assembled, free-hanging ceiling canopy with circumferential metal frame and with integrated workplace luminaire as an option.

The canopy is suspended on wire ropes or in groups, hence free circulation of air (important in thermal activation of concrete ceilings)



Element selection:

- Standard (flammability) 3S_33 ▶ page 6
- Note: Canopies are delivered fully configured

Application

Grid ceiling

Readily cut pieces of LIGNO® Acoustic light panels can be fit into existing grid ceiling structures..



Element selection:

- Standard (flammability) 3S_33 ▶ page 6

Application

Wall panelling / element installation in the stretching bond

Use of elements in standard length 2940 mm

Notes:

- Frontal butts are identifiable on the surface.
- Installation with vertical or horizontal gap pattern.
- Little offcut: The section of the last element is being used as the first element in the next row each time.

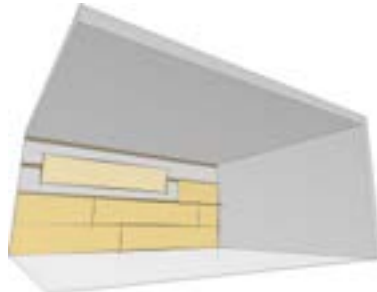

Element selection:

- **Standard (flammability)** 3S_33 ▶ page 6
- **Fire retardant** special configuration with
 - _C-s2-d0 3S_33
 - _B-s2-d0 3G_33
 - _B-s1-d0 3S_40
 ▶ page 9
to DIN EN 13501-1

Application

Impact wall, acoustically effective

Fitting of elements on special, force-reducing substructure (elastic brace and counterbrace configuration, force reduction checked).

Installation with horizontal joint pattern.

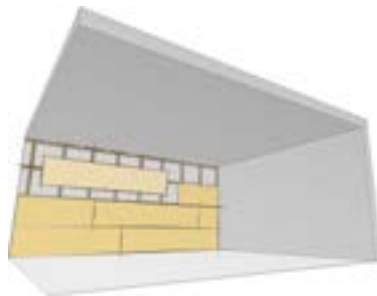

Element selection:

- **LIGNO® Acoustic Sport 3G_33**
- ▶ **Technical data sheet LIGNO® Acoustic Sport**

Green building

LIGNO® Akustik is natureplus® certified. This means that the product fulfils the highest requirements for healthy indoor climate, sustainability and climate protection. Extensive tests provide a comprehensive basis for the certification of buildings (characteristic values on request).

- Compliance with stringent emission limit values
- Functional and quality criteria
- Origin of the wood (FSC/PEFC sources), sustainable production of the elements
- Life cycle analysis

The certificate according to guideline RL0201 covers the untreated basic element in fir/spruce.



Element designation and configuration overview

Sample configuration: LIGNO® Acoustic light 3S_33_a70g_625-12-4_WTL_gb_buv

1. Form of base element ▶ page 6

LIGNO® Acoustic light 3S_33_a70g_625-12-4_WTL_gb_buv



3S_33



Rear layer open

3S_39 / 3S_40



Rear layer open
Visible layer thicker

3G_33

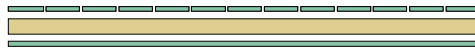

Rear layer largely closed

3S_62 ▶ TD LIGNO® Acoustic light - Individual length

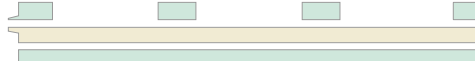

Rear layer open and thicker
Visible layer thicker

2. Absorber layer ▶ from page 12

LIGNO® Acoustic light 3S_33_a70g_625-12-4_WTL_gb_buv



_a70g

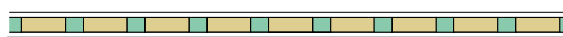

_a10g



_a50l



3. Acoustic profile ▶ page 12

LIGNO® Acoustic light 3S_33_a70g_625-12-4_WTL_gb_buv



_625-12-4

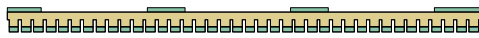

Ledge width: 12 mm
Gap width: 4 mm

_625-20-4 / _625-20-4-F

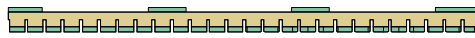

Ledge width: 20 mm (optionally with chamfered edges)
Gap width: 4 mm

_625-12n25-4

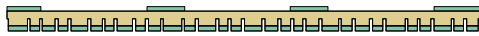

Slat width: 12-25 mm
Gap width: 4 mm

_625-12n25-4:3D

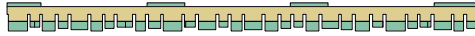

Slat width: 12-25 mm, Strip height offset
Gap width: 4 mm

_625-22n40-4 / _625-22n40-4-F

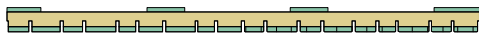

Slat width: 22-40 mm (optionally with chamfered edges)
Gap width: 4 mm

_625-23-8

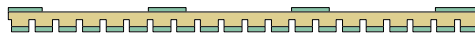

Slat width: 23 mm
Gap width: 8 mm

_625-18-6



Slat width: 18 mm
Gap width: 6 mm

_625-18n38-6

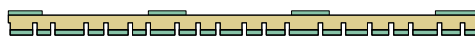

Slat width: 18-38 mm
Gap width: 6 mm

4. Wood surfaces ▶ page 8

LIGNO® Acoustic light 3S_33_a70g_625-12-4_WTL_gb_buv



_WTL

Silver fir, patterned



_WTS

Silver fir, plain



_FI-ä

Spruce with knots (A-quality)



_LÄE

Larch knotless, european



_BI

Birch knotless



_ESL

Ash knotless, patterned



_PA-ä

Poplar with fine knots



_WTL-i

Silver fir, impregnated



_DO

Douglas fir knotless



_HE

Hemlock fir knotless



_ZI-ä

Stone pine with knots



_BU

Beech knotless



_KB

Cherry knotless



_WTE

Silver fir, economy



_FIS

Spruce knotless, plain



_KI

Pine knotless



_AHE

Maple knotless, european



_EI

Oak knotless



_NAL

Walnut knotless, patterned



_WTD

Silver fir knotless without junction



_FIS-i

Spruce knotless, impregnated



_LÄS

Larch knotless, siberian



_AHK

Maple knotless, canadian



_EIF-i

Oak knotless, veneer



_NAE

Walnut knotless, elegant



5. Surface finish

LIGNO® Acoustic light 3S_33_a70g_625-12-4_WTL_gb_buv



_gb

brushed

_gs

evenly sanded brushed

_gr

rough sawn

6. Surface treatment ▶ page 10

LIGNO® Acoustic light 3S_33_a70g_625-12-4_WTL_gb_buv



_b0

untreated

_buv

with UV-protection

_bh-t

oil transparent

_bh-w10

oil translucent whitish

_bh-w20

oil nearly opaque

_bl-t

lacquer transparent

_bl-w10

lacquer translucent whitish

_bl-w20

lacquer nearly opaque

_bl-w10k

chalked-up, lacquer transparent

_bd-a

old wood decor (print)

_bd

photo print

Type 3S_33 Geometry

Application ▶ from page 2

Availability

- Only in standard length 2940 mm
- Normally inflammable, selected profiles also with a flame-retardant surface if the appropriate wood surface **_C-s2-d0** ▶ page 9

View

Timber slat profile

Wood types and profile alternatives ▶ from page 8

Absorber type _a70g

Approx. 70 % absorber portion in the transverse layer, absorber: Wood fibre

Lateral section:

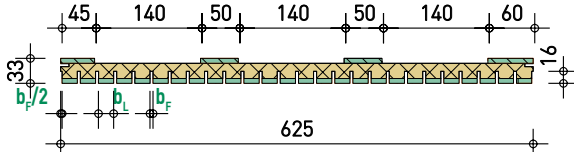

Longitudinal section:

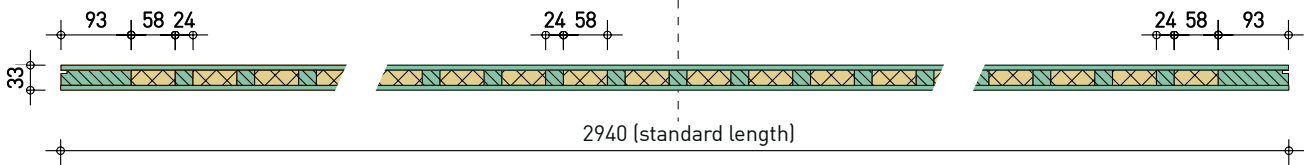

! Information on tolerance regarding elements' internal structure:

Internal element structure: With constant total thickness of the element, the thickness of the visible and the rear layer can vary by approx. $\pm 0,5$ mm. Also, the position of absorber strips and timber transversal layer can vary in the range of millimetres for production-related reasons. Depths of acoustic gaps can vary from 14 to 16 mm.

Edging **_nnu** (standard):

Circumferential groove, matching plywood tongue is included

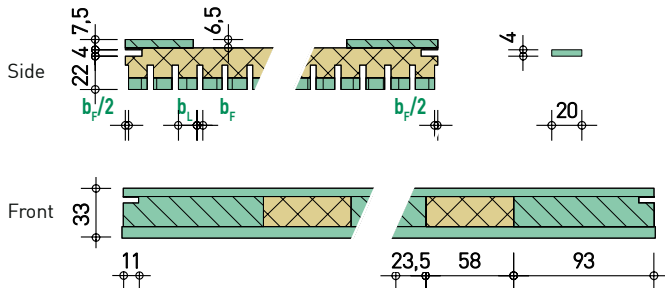

Variant _a10g (low absorption)

Rigid transverse layer with relieving strip (wood fibre)

Lateral section:

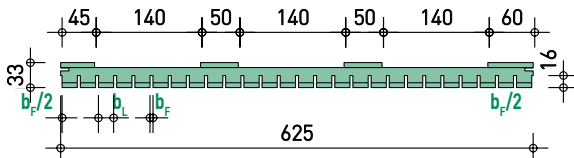

Longitudinal section:

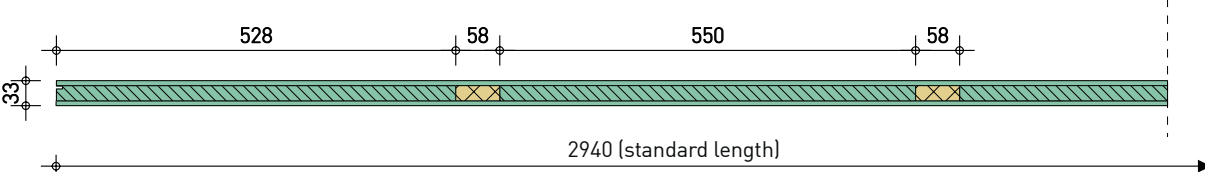

Note: Higher weight! ▶ see page 30

Type 3G_33 Geometry

Application ▶ from page 2

Availability

- only in standard length 2940 mm
- Normally inflammable, selected profiles also with a flame-retardant surface if the appropriate wood surface **_B-s2-d0**, with colour treatment **_C-s2-d0** ▶ pages 9

View

Timber slat profile

Wood types and profile alternatives ▶ from page 8

Absorber type _a70g

Approx. 70 % absorber portion in the transverse layer, absorber: Wood fibre

Lateral section:

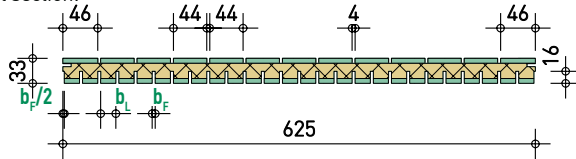

Longitudinal section:

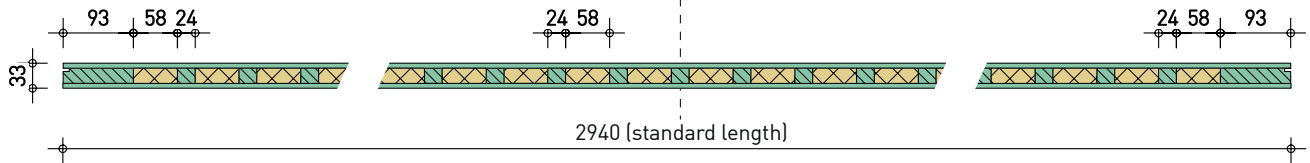

! Information on tolerance regarding elements' internal structure:

Internal element structure: With constant total thickness of the element, the thickness of the visible and the rear layer can vary by approx. $\pm 0,5$ mm. Also, the position of absorber strips and timber transversal layer can vary in the range of millimetres for production-related reasons. Depths of acoustic gaps can vary from 14 to 16 mm.

Variant _a10g (low absorption)

Rigid transverse layer with relieving strip (wood fibre): See Type 3S-33, Note: higher weight! ▶ see page 30

Type 3S_39 (for 3D-Profile) Geometry

Thicker type for the height-graduated nature profile **_625-12n25-4:3D**. The strips are graduated in height in an irregular sequence of 0, 2, 4 and 6 mm. Absorber/rear layer and groove position relative to the rear side are identical to type 3S_33.

Lateral section:

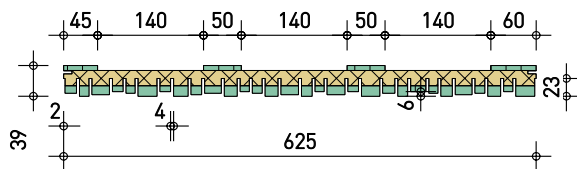

Longitudinal section:

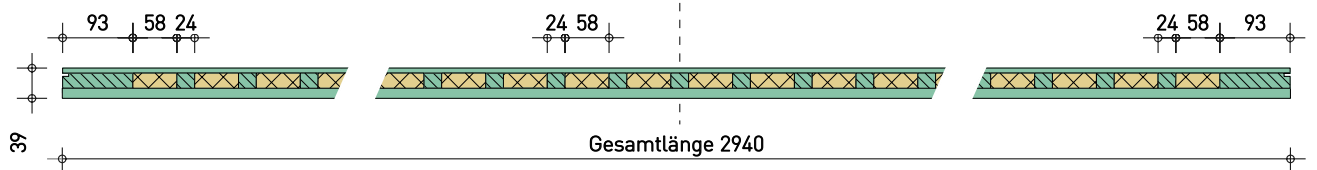

! Information on tolerance regarding elements' internal structure:

Internal element structure: With constant total thickness of the element, the thickness of the visible and the rear layer can vary by approx. $\pm 0,5$ mm. Also, the position of absorber strips and timber transversal layer can vary in the range of millimetres for production-related reasons.

Notes:

- a three-dimensional profiling is **only possible in the wood species Silver fir and Oak** ▶ page 8
- any **surface treatment only by customer**, likewise ex works only without structural brushing
- absorptive effect is comparable to elements with flat nature-profile of type **_625-12n25-4** without 3D-profiling

Surface

Available wood species

The surfaces are manufactured from one-ply-panels consisting of narrow lamellas. In the case of knotless sorting, the individual lamellas consist of pieces being largely free of knots, connected through finger joints in length. Most surfaces of the acoustic panels usually have received structural brushing.

For exact details and large pictures refer to the data sheet ► [TD LIGNO® Surfaces](#) and to ► www.lignotrend.com/surfaces

Profile	3S_33 / 3G_33							3S_39	3S_40		
	_625-12-4	_625-12n25-4	_625-20-4	_625-22n40-4	_625-18-6	_625-18n38-6	_625-23-8	_625-12n25-4:3D	_625-12-4	_625-12n25-4	_625-18-6
Silver fir knotless, patterned _WTL	■	■	■	■	■	■	■	■	☒	☒	☒
Silver fir knotless, impregnated _WTL-i	□	□	□	□	□	□	☒	☒	■	■	■
Silver fir knotless, economy _WTE	■	■	■	■	■	■	■	■	☒	☒	☒
Silver fir knotless without junction _WTD	□	□	□	□	□	□	□	☒	☒	☒	☒
Silver fir knotless, plain _WTS	□	□	□	□	□	□	□	☒	☒	☒	☒
Douglas fir knotless _DO	□	□	□	□	□	□	□	☒	☒	☒	☒
Spruce knotless, plain _FIS	■	■	■	■	■	■	■	☒	☒	☒	☒
Spruce knotless, plain impregnated _FIS-i	■	■	■	■	☒	☒	☒	☒	☒	☒	☒
Spruce with knots (A-qual.) _FI-ä	□	□	□	□	□	□	□	☒	☒	☒	☒
Hemlock fir knotless _HE	□	□	□	□	□	□	□	☒	☒	☒	☒
Pine knotless _KI	□	□	□	□	□	□	□	☒	☒	☒	☒
Larch knotless, siberian _LÄS	□	□	□	□	□	□	□	☒	☒	☒	☒
Larch knotless, european _LÄE	□	□	□	□	□	□	□	☒	☒	☒	☒
Stone pine with knots _ZI-ä	□	□	□	□	□	□	□	☒	☒	☒	☒
Maple knotless, european _AHE	□	□	□	□	□	□	□	☒	☒	☒	☒
Maple knotless, canadian _AHK	□	□	□	□	□	□	□	☒	☒	☒	☒
Birch knotless _BI	□	□	□	□	□	□	□	☒	☒	☒	☒
Beech knotless _BU	□	□	□	□	□	□	□	☒	☒	☒	☒
Oak knotless _EI	□	□	□	□	□	□	□	■	☒	☒	☒
Oak knotless, veneer _EIF-i	□	□	□	□	□	□	☒	☒	☒	☒	☒
Ash knotless, patterned _ESL	□	□	□	□	□	□	☒	☒	☒	☒	☒
Cherry knotless _KB	□	□	□	□	□	□	□	☒	☒	☒	☒
Walnut knotless, patterned _NAL	□	□	□	□	□	□	□	☒	☒	☒	☒
Walnut knotless, elegant _NAE	□	□	□	□	□	□	□	☒	☒	☒	☒
Poplar with fine knots _PA-ä	□	□	□	□	□	□	□	☒	☒	☒	☒

■ possible ■ possible extended delivery time □ not recommended because of outbreaks ☒ not available

Surface Flame retardancy

Available only for selected alternatives according to the table below. By using an appropriately impregnated surface layer, acoustic panels LIGNO® Acoustic light or LIGNO® Acoustic Sports are produced with flame-retardant surface. Classification in accordance with DIN EN 13501-1.

Flame-retardant surfaces **cannot be UV-protected**.

Surfaces that have been treated with varnish or oil the reaction to fire class deteriorates.

Classified panel design according to profile, element type and wood species.

Classification	625-12-4	625-20-4	625-20-4-F	625-12n25-4	625-18-6	625-18n38-6	625-23-8
Standard flammability	<input type="checkbox"/> <input checked="" type="checkbox"/>	<input type="checkbox"/> <input checked="" type="checkbox"/>	<input type="checkbox"/> <input checked="" type="checkbox"/>	<input type="checkbox"/> <input checked="" type="checkbox"/>	<input type="checkbox"/> <input checked="" type="checkbox"/>	<input type="checkbox"/> <input checked="" type="checkbox"/>	<input type="checkbox"/> <input checked="" type="checkbox"/>
	LIGNO® Acoustic light 3S_33						
	<input type="checkbox"/> <input checked="" type="checkbox"/>	<input type="checkbox"/> <input checked="" type="checkbox"/>	<input type="checkbox"/> <input checked="" type="checkbox"/>	<input type="checkbox"/> <input checked="" type="checkbox"/>	<input type="checkbox"/> <input checked="" type="checkbox"/>	<input type="checkbox"/> <input checked="" type="checkbox"/>	<input type="checkbox"/> <input checked="" type="checkbox"/>
	LIGNO® Acoustic light 3S_33 WTL / FIS / EI + 30 mm Timber substructure incl. 30 mm mineral wool LIGNO® Acoustic light / Acoustic Sport 3G_33_WTL / FIS / EI						
fire retardant	<input type="checkbox"/>	<input type="checkbox"/>	<input type="checkbox"/>	<input type="checkbox"/>	<input type="checkbox"/>	<input type="checkbox"/>	not possible
	LIGNO® Acoustic light 3S-33_WTL-i 3S-33_EIF-i 3S-33_FIS-i	LIGNO® Acoustic light 3S-33_WTL-i 3S-33_FIS-i		LIGNO® Acoustic light 3S-33_WTL-i 3S-33_FIS-i	LIGNO® Acoustic light 3S-33_WTL-i 3S-33_FIS-i	LIGNO® Acoustic light 3S-33_WTL-i 3S-33_FIS-i	
	<input checked="" type="checkbox"/>	<input checked="" type="checkbox"/>	<input checked="" type="checkbox"/>	<input checked="" type="checkbox"/>	<input checked="" type="checkbox"/>	<input checked="" type="checkbox"/>	not possible
	LIGNO® Acoustic light 3G-33_WTL-i	LIGNO® Acoustic light 3G-33_WTL-i	LIGNO® Acoustic light Acoustic Sport 3G-33_FIS-i	LIGNO® Acoustic light 3G-33_WTL-i	LIGNO® Acoustic light 3G-33_WTL-i	LIGNO® Acoustic light 3G-33_WTL-i	
	<input type="checkbox"/>	<input type="checkbox"/>	<input type="checkbox"/>	<input type="checkbox"/>	<input type="checkbox"/>	<input type="checkbox"/>	not possible
	LIGNO® Acoustic light 3G-33_WTL-i	LIGNO® Acoustic light 3G-33_WTL-i 3G-33_FIS-i	LIGNO® Acoustic light Acoustic Sport 3G-33_FIS-i	LIGNO® Acoustic light 3G-33_WTL-i	LIGNO® Acoustic light 3G-33_WTL-i	LIGNO® Acoustic light 3G-33_WTL-i	
	<input type="checkbox"/>			<input type="checkbox"/>	<input type="checkbox"/>		not possible
	LIGNO® Acoustic light 3S-40_WTL-i			LIGNO® Acoustic light 3S-40_WTL-i	LIGNO® Acoustic light 3S-40_WTL-i		

without further surface treatment

with painted and oiled surface

Important note concerning the reaction of flame-retardant surfaces to potentially increased humidity

Timber impregnated with fire retardants tends to absorb moisture from the indoor air and concentrate it. To prevent moistening of the visible surface the **elements with impregnated surfaces may only be installed in closed rooms with temperatures > 15 ° C relative humidities < 75 % under normal use**. If these boundary conditions are met, the elements can also be installed in air-conditioned and ventilated indoor aquatic centres.

In case of unfavorable climatic conditions during installation, moisture may cause optical changes (stains) to the visible surface. However, after normalization of the indoor climate, the stains disappear without residue. If unpredictable and unfavorable parameters lead to such moistening of the surfaces, appropriate measures must be taken to dry the room air until a normal climate of approx. 20 ° C and humidity of < 50 %.

Surface Primer / finish / light reflectance

According to the table below, panels can be provided ex works with a primer or final treatment applied on their surface. Because of the variety of options, normally we only provide elements with final treatment after approval of an original sample.

	Without treatment	UV protective primer	Oiled finish				Painted finish				
	_gb brushed surface	_gb sbrushed surface	_gb brushed surface ³				_gs evenly sanded surface				
	No treatment ¹ _b0	Transparent UV-protective primer against darkening ² _buV	Transparent _bh-t	Whitish, grain shining through _bh-w10	White _bh-w20	Coloured _bh-xy	Transparent _bl-t	whitish, grain shining through _bl-w10	White _bl-w20	Coloured according to RAL/NCS _bl-xy	Chalked-up and with transparent lacquer _bl-w10k
Silver fir knotless patterned _WTL	■	■	■	■	■	■	■	■	■	■	□
Silver fir knotl. patterned, impregnated _WTL-i	■	□	■	■	■	■	■	■	■	■	□
Silver fir knotless plain _WTS	■	■	■	■	□	□	■	■	□	□	□
Silver fir knotless economy _WTE	■	■	■	□	□	□	■	□	□	□	□
Spruce, knotty (A-quality) _FI-ä	■	■	■	■	□	□	■	□	□	□	□
Spruce knotless, plain _FIS	■	■	■	■	■	■	■	■	■	■	□
Spruce knotless, plain, impregnated _FIS-i	■	□	■	■	■	■	■	■	■	■	□
Larch knotless, siberian _LÄS	■	□	■	■	□	□	□	□	□	□	□
Oak knotless _EI	■	□	■	□	□	□	■	□	□	□	■
Beech knotless _BU	■	□	■	□	□	□	■	□	□	□	□
Stone pine with knots _ZI-ä	■	□	■	□	□	□	■	□	□	□	□

¹ Surface can be treated on site with paints / glazes appropriate for the type of wood.

■ possible □ not recommended □ not possible

² Suitable for indoor use (not classified toxic). Based on water-soluble photoprotective agents, must be treated on site against water with a glaze, when washing-out cannot be excluded. Finish for example with transparent lacquer.

Caution: Treatment necessary after repair, for example by grinding.

³ For reasons of brushing, it may happen that some slats appear matt in sided light because of varying fibre orientation.

Light reflection properties of surfaces

Reflectance measurement according to DIN 5036 part 3	Finish with oil _bh-w10	Finish with oil _bh-w20	Finish with oil _bl-w10	Finish with oil _bl-w20	Transparent UV-protective primer _buV
_625-12-4	50	60	55	60	50
_625-20-4	55	60	60	60	55
_625-12n25-4	55	60	60	65	50

Overview substructures

Ball impact resistance and force dissipation

For acoustic elements LIGNO® Acoustic with strip surface, the ball-impact resistance is tested for various installation variants in use on wall or ceiling according to DIN 18032-3:2018-11. Test certificates can be requested. ► www.lignotrend.com/downloads

Requirements according to DIN 18032-3:2018-11	Type	Panel ar- rangement	Substructure		Grid dimension		Suspension height	
			Wood	Metal	Base profile	Support profile	min.	max
Ceiling Ball impact tested with handball 65 km/h	LIGNO® Acoustic light 3S_33 / 3G_33 Wood species: all Profiles: all (except 625-12n25-4:3D)		Single battens Multi-layered board strips (95 x 27 mm) PZ 903 8441 000-2_Sgm			625 mm	30 mm	1000 mm
			Cross grid Multi-layered board strips (95 x 27 mm) PZ 903 8441 000- 1_Sgm		800 mm	625 mm		
			Cross grid Solid structural timber (50x30 mm) PZ 903 8441 000-3_Sgm		1 000 mm	625 mm		
				Cross grid CD profile 60/27/06 PZ 903 5779 000-1_Man_Sgm	800 mm	490 mm or 735 mm		
Wall Ball impact tested with handball 85 km/h	LIGNO® Acoustic light / Sport 3G_33 Wood species: WTL / FIS / BU / EI Profiles: all (except 625-12n25-4:3D) Above impact wall (>2.0 m FFL)	horizontal and vertical	Single battens at a right angle to the acoustic panel PZ_L_7543/MK	Single battens at a right angle to the acoustic panel PZ_L_7543/MK		490 mm	40 mm	
			Single battens at a right angle to the acoustic panel PZ_L_7542/MK	Single battens at a right angle to the acoustic panel PZ_L_7542/MK				
Impact wall ► LIGNO® Acoustic Sport force dissipating for school sports facilities according to GUV-SI 8469 Ball impact tested with handball 85 km/h and hockey ball 65 km/h	LIGNO® Acoustic Sport 3G_33 Wood species: FIS / BU / EI Profiles: 625-20-4-F / 625-22n40-4-F Impact wall area < 2.0m FFL	horizontal	Screwed vertical battens and hori- zontal vibration battens PB_L_7025		625 mm	735 mm	56 mm	100 mm
				Vertical C-profile with spring element PB_L_7023			735 mm	60 mm
		vertical	Screwed vertical battens and hori- zontal vibration battens PB_L_7025		625 mm	735 mm	56 mm	100 mm
				Vertical C-profile with spring ele- ment and Screwed horizontal battens PB_L_7024		625 mm	735 mm	60 mm

Absorber layer and acoustic profile

Acoustic absorber

In the elements' intermediate layer, timber and acoustic strips in different arrangements are placed in right angle to the visible ledge profile:

Type	Explanation	Certificate
_a70g	Standard absorber (approx. 70% of the intermediate layer) Absorber material: Wood fibre, slightly water-repellent (make: Gutex Thermosafe, natureplus certificate no 0104-0710-012-4)	
_a10g	Absorber layer for low-absorbing element variant: Here, the central layer is made of solid wood with only isolated relaxation strips made of soft wood fibre. Slightly increased element weight.	

Acoustic profile

The surface layer will be furnished with a fine slat profile. Behind the gaps, an absorber material acoustically effective is already integrated in the elements' production (standard: wood fibre).

Profile type	Gap width b_F	Slat width b_L	No of slats per element
regular-Profil _625-12-4	4 mm	ca. 12,5 mm	38
regular-Profil _625-18-6	6 mm	ca. 18 mm	26
regular-Profil _625-23-8	8 mm	ca. 23,3 mm	20
regular-Profil _625-20-4	4 mm	ca. 20 mm	26
nature-profile _625-12n25-4	4 mm	ca. 12-25 mm	
nature-3D-profile _625-12n25-4:3D	4 mm	ca. 12-25 mm (graduated ledge heights of 0 to 6 mm)	
nature-profile _625-22n40-4	4 mm	ca. 22-40 mm	
nature-profile _625-18n38-6	6 mm	ca. 18-38 mm	

[Other profiles on request](#)

Characteristics for flame retardancy and ball-impact resistance of acoustic profiles ► [from page 9](#)

Important note on selecting the acoustic profile

The profile with **_625-12-4** should be avoided on large continuous wall surfaces in rather small rooms because this may result in optical irritations. Remedy: Pictures, darkly-treated partial areas, interruption through areas without relief pattern, choice of profile **_625-20-4** or **_nature-profile**. The slat profile with 8 mm gap can be disadvantageous for the wall because the joints become transparent depending on light conditions and any staggered transverse layers would be seen.

Installation on wood substructure (single battens)

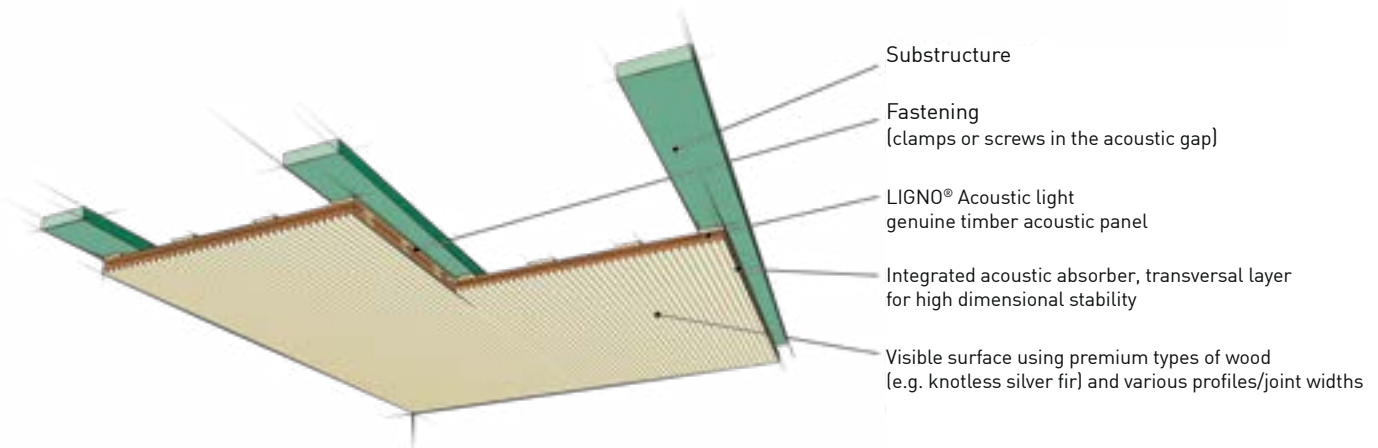

1. Substructure

- Elements LIGNO® Acoustic light of type **3S-33**, **3S-39** and **3G-33** are in standard installed on a **substructure running parallel to the elements' length**.
- Material for substructure:
Wooden batten (rectangular section): min. 27/95 mm, pitch 625 mm, stripes of 3-ply-panels recommended. ► [see page 11](#)
- Also place substructure around openings and alongside the edges of the wall/ceiling.
- Only use connectors approved for the building structure's material!
- Exactly level the substructure's lower edge horizontally.

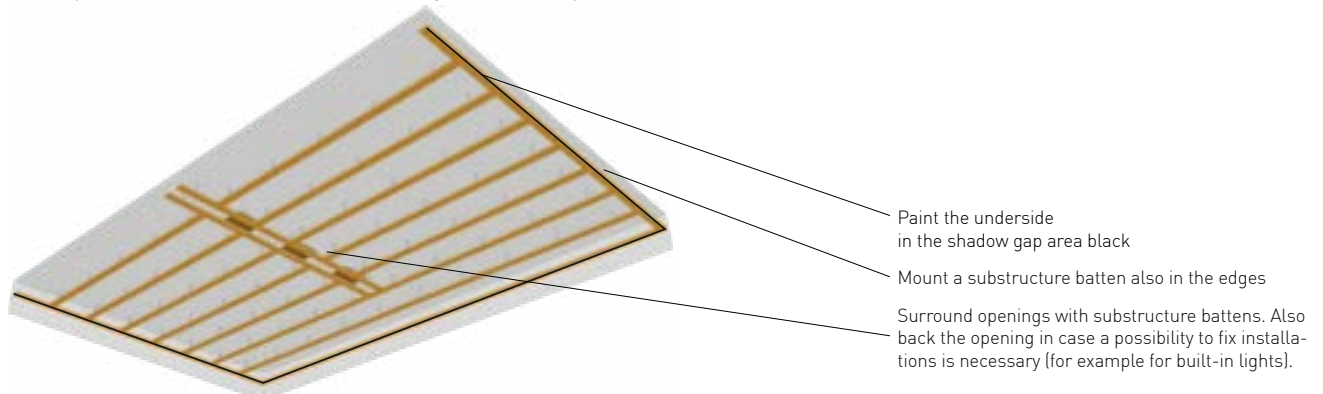

- Installation substructure directly to the building structure, Line if necessary (e.g. for reason of structure's unevenness).

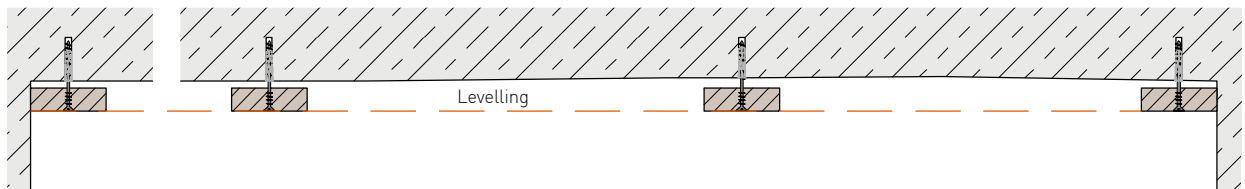

- Alternative: Installation of substructure with suspension system suitable for wooden battens, e.g. two-piece "Nonius" type metal suspending brackets with bottom part designed for screw-on fixing on wood. Mind the manufacturer's specifications!

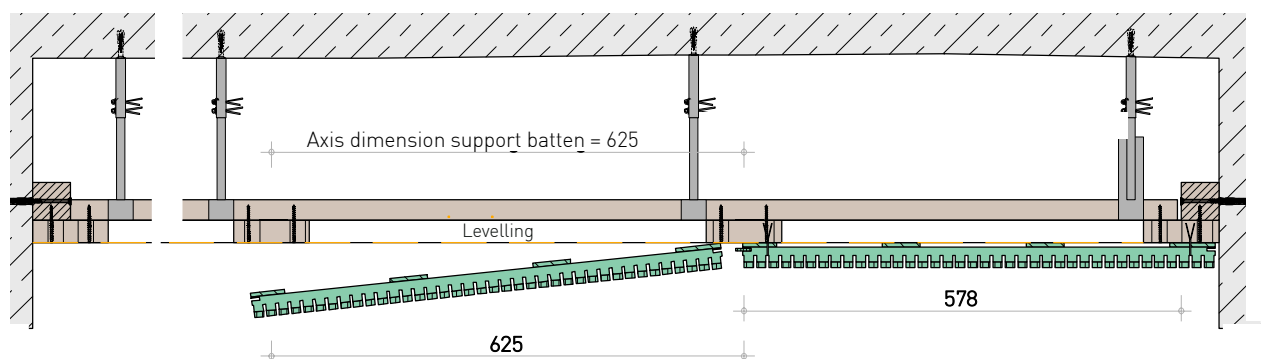

2. Element installation, first rows

- Prepare all cuttings on the ground, also openings for components to build in.

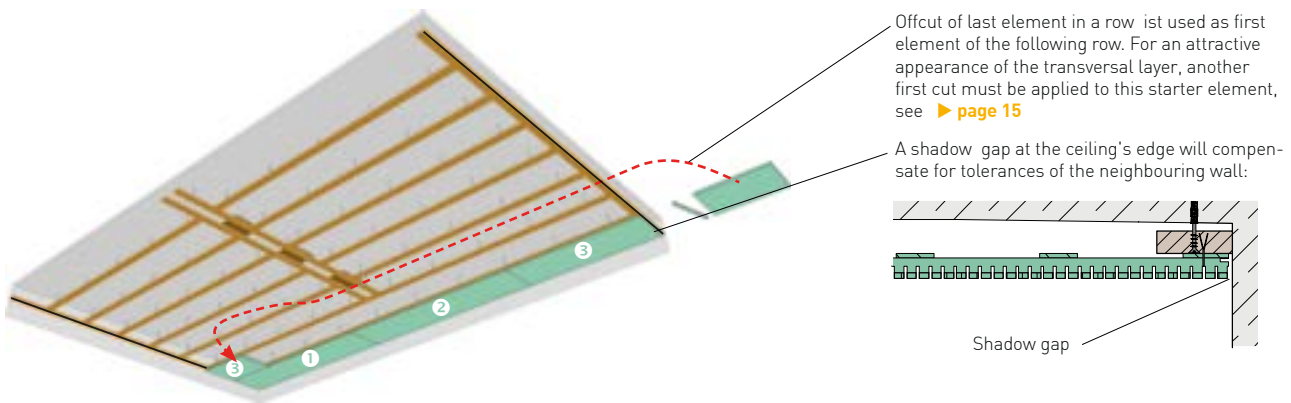

- Due to natural variation of timber's moisture content, under certain circumstances, gaps more or less clearly visible can occur at the frontal joints. To avoid this, it is highly recommended to back the panels at this joint with an additional board which is being set with screws and glue.

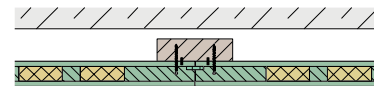

- All connection material must be applied in line with the elements' intermediate transversal layers' axis which is visible through the acoustic gaps, application of any fasteners through the wood fibre absorber is not allowed!

- Standard fastening with clamps (concealed, in the acoustic gaps)

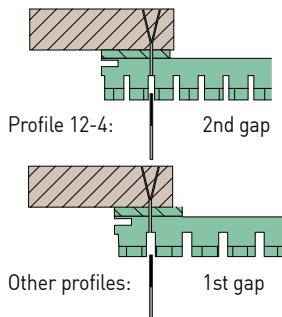

- Appropriate compressed-air staple gun: Air-stapler K.M. Reich, type 3428 with foot for Lignotrend-acoustic panels, available from Lignotrend (also to be leased).
- clamps, approx. 10 pcs. per panel (dependent on load, in doubt provide proof)
- Observe the edge distance on the element:
Clamp in the second edge gap when using profiles with 12 mm ledges!

- Alternative fastening with special screws (concealed, in the acoustic gaps)

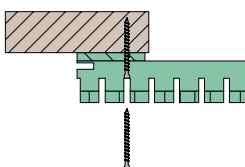

- Use a **self-drilling fully-thread screw 3.5 x 40 (V4A)** with narrow head, approx. 12-16 pcs. per panel (if the frontal joint of the panels shall be lined, the higher quantity of screws should be calculated). Special screws and suitable inserts (bits) with prolonged tip are available from Lignotrend).
- Using screws in the gap lets them almost completely disappear from view.

In order for the panel to be in full contact with the substructure, it must be pressed on when screwing, e.g. by means of a clamp.

If a gap is created, the full-thread screw must be unscrewed a little and then screwed in again after pressing on.

3. Cuttings

- **Look out for sharp tools!**
- Straight sections: Use circular saw and rail
- Openings: Use a drill bit tube or jigsaw.
Secure slats against breaking off before drilling and / or use a drilling template!

Secure the slats while drilling: In the zone of the hole, loosely insert stripes of wood in the gaps' thickness (4/6/8 mm wide, approx. 16 mm high)

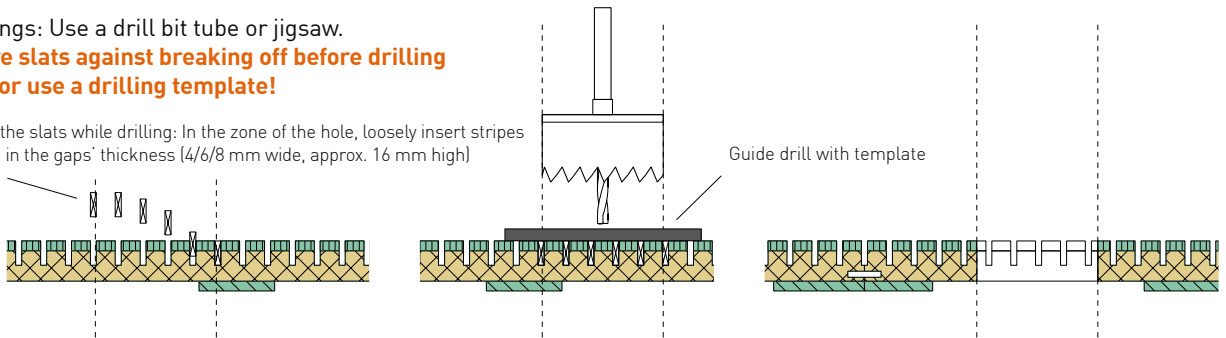

- **Check approval for installation in timber panels before installation of any parts, especially electric components as lamps. Always refer to manufacturer's specifications!**

4. Element installation, further rows

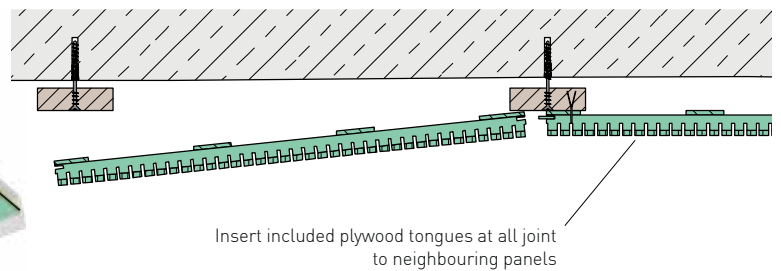
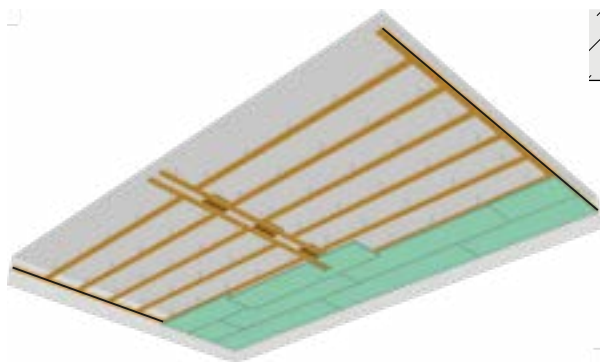

- Normally, the elements are installed in the stretching bond: The last offcut piece of a row is being used as starting piece of the following row.
- Note for wall panellings and other panellings with acoustic gaps of more than 4 mm width: In case of unfavourable lighting conditions, the transversal layers behind the gaps can be recognisable. To accomplish a good appearance of the lateral joint, you should mind to have the transversal layers of adjoining elements aligned.

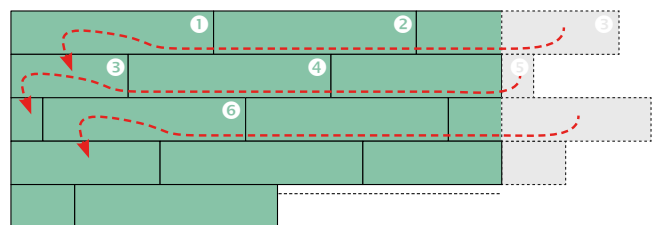

! Cut the first element per row in length in such a way that the transverse layers are aligned with those of the preceding row.

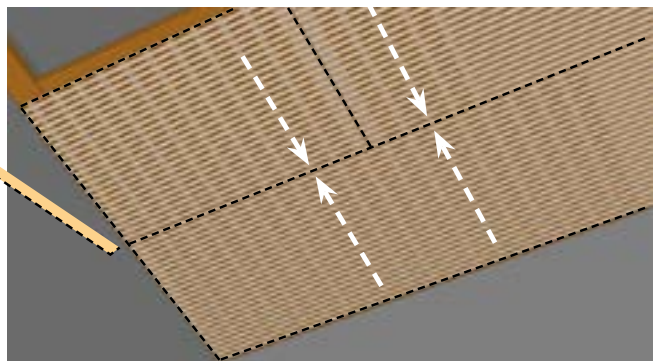

5. Element fastening alongside edges and around openings

- Also fasten elements in the middle of the element width alongside openings (use clamps or screws in the gaps), because minimal deformations of the elements might disturb the overall visual impression.

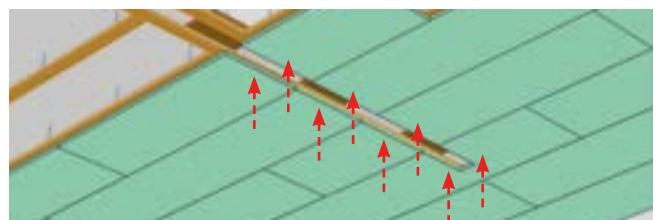

Installation on metal substructure (cross grid)

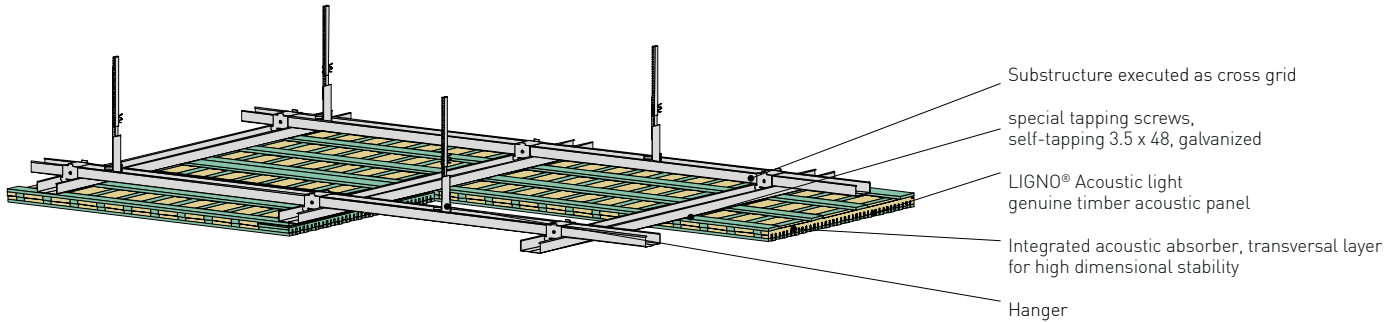

1. Substructure

- LIGNO® Acoustic light elements type **3S_33** and **3G_33** are mounted as standard on a **substructure running transversely to the element**.
- Material for substructure:
 - CD profile (dimensions 60 / 27 / 06) according to DIN 18182 for support and assembly profile
 - Matching cross connector for CD profile
 - Matching multi-connector and universal connector for CD profile
 - Drywall screws TN fine thread for optimal securing of the connectors
 - Nonius or direct hangers with a load capacity of 0.4 kN
- Arrange substructure along openings.
- Wall connection with profile UD 28 / 27, fastening distance < 625 mm
- Use only fasteners that are suitable for the substrate
- Level the substructure exactly horizontally

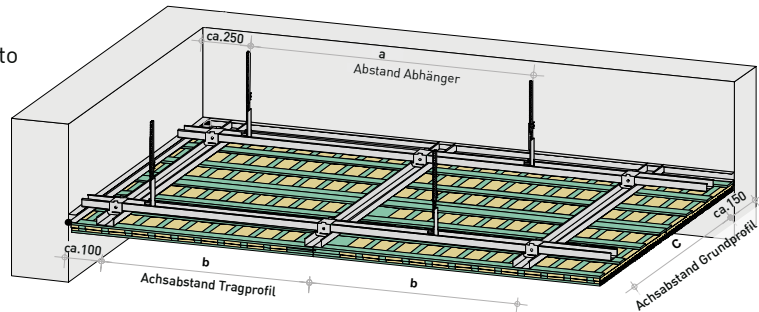

Umlaufendes UD-Profil für den Anschluss im Wandbereich

Base and support profile	No fire protection requirement	With fire protection requirement
Hanger a	800 mm	800 mm
Base profile c	800 mm	800 mm
Support profile b	735 mm	572 mm

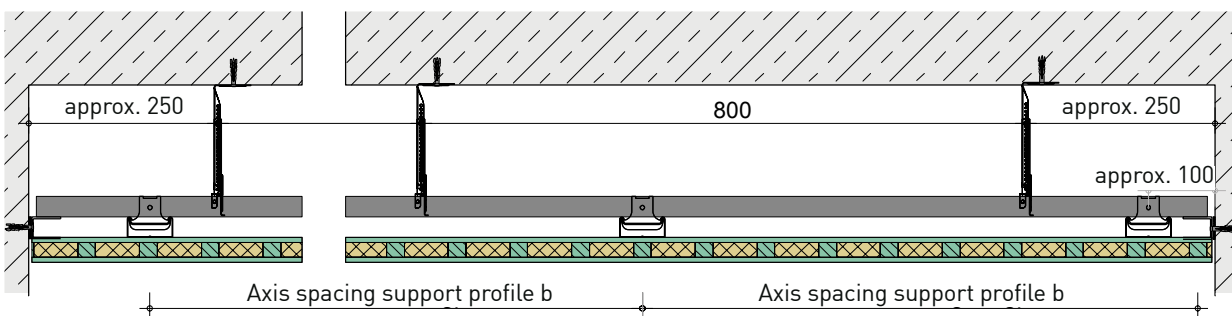

- Alternatively, the suspension can be done with direct hangers of the same load capacity in the grid shown.
- **The use of quick hangers in combination with LIGNO® acoustic panels is not recommended due to insufficient load capacity!**

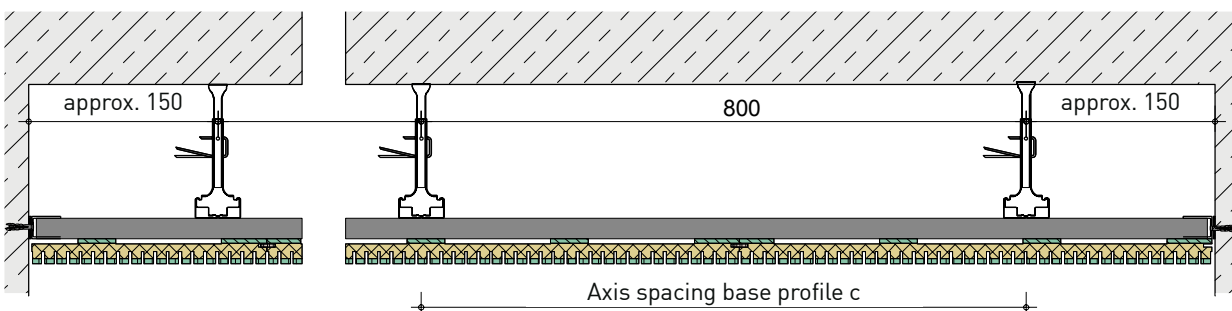

2. Element installation, first row

- Cuttings and openings for components to build in. ► [page 15](#)
- Make openings on the base.

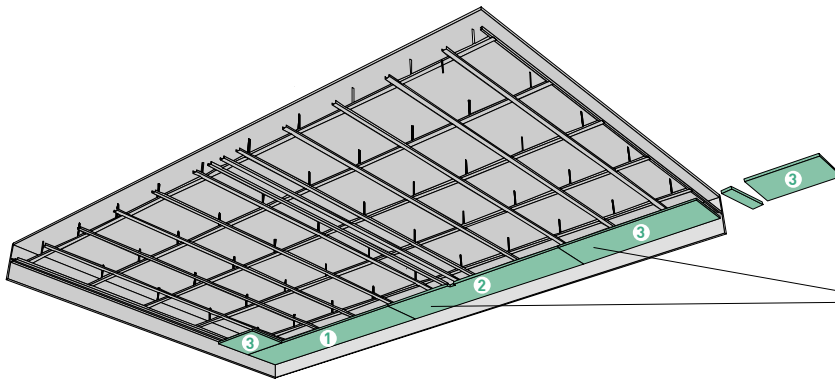

Section of the last element of a series is used as the first element in the following series. **Element length must correspond to at least one grid length!** For a regular transverse layer pattern, the section must be cut again analogous to the timber substructure

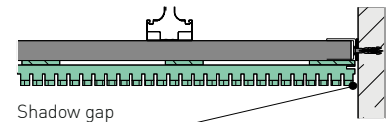

At the facing joints, more or less clearly recognisable joints can form due to the natural wood moisture fluctuation. Should this be excluded, it is strongly recommended to connect the panels there rigidly with a board placed behind, which is fixed by screwing and gluing.

- **Fasteners may only be placed in the axis of the transverse layer recognisable in the acoustic gaps; fastening through the absorber is not permitted!**
- Standard fastening with special sheet metal screws (not visible in acoustic gaps)

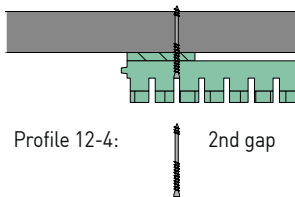

- Non-combustible substructure made of galvanized steel sheet profile
- CD profile according to DIN 18182, dimensions 60 / 27 / 06 in the cross grid transverse to the element grid support profile adapted to the element transverse layer ► [page 11](#)
- Fix the element for installation with a clamp.
- Fastening: **Special sheet metal screw 3.5 x 48 galvanized**

3. Cuttings

- See chapter "Installation on wood substructure" ► [from page 15](#)

4. Ceiling openings for fittings such as inspection openings

- Execute substructure as double profile grid at openings such as inspection flaps

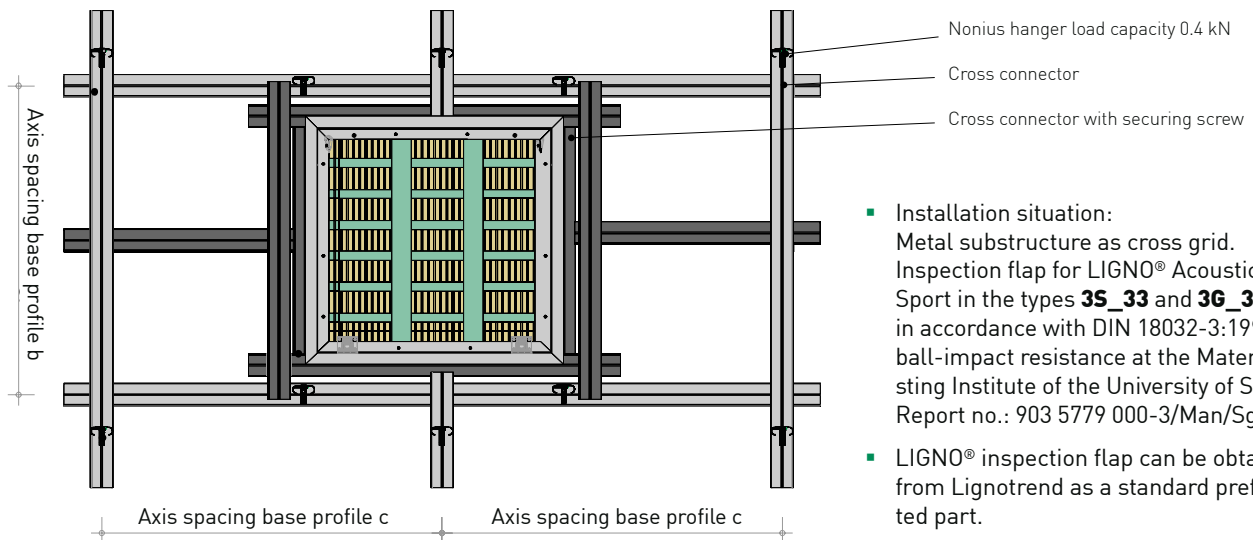

- Installation situation: Metal substructure as cross grid. Inspection flap for LIGNO® Acoustic light / Sport in the types **3S_33** and **3G_33** tested in accordance with DIN 18032-3:1997-04 for ball-impact resistance at the Materials Testing Institute of the University of Stuttgart. Report no.: 903 5779 000-3/Man/Sgm
- LIGNO® inspection flap can be obtained from Lignotrend as a standard prefabricated part.

- Extensive installation instructions for inspection flap installation ► [Inspection flap installation instructions](#)

5. Element installation of further rows, Element fixing along edges and openings

- See chapter "Installation on wood substructure" ► [from page 15](#)

Installation in extraordinary locations

Special execution of substructure in case of demands for low flammability

Flame retardant substructure

Use impregnated battens (available from Lignotrend).
Installation parallel to the elements' length, pitch 625 mm.
Deviant fastening in impregnated battens
with **fully-thread screw 3,5 x 40 stainless steel (V4A)**
oder **Knoll-clamps type G material no. 1.4301**
(Insert screw or clamp into gap.)

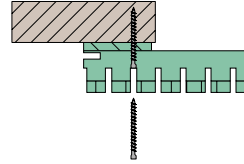

Noncombustible substructure

Use zinc coated steel sheet profile, e.g. CD 60/27 (DIN 18182),
Deviant installation at right angle to elements' length,
Pitch adjusted to distance of element's transversal layers,
e.g. 567 or 648 mm. Use special NF-panels, temporarily fix
element with clamp. Fastening: **Special metal tapping screw**
3,5x 48 (galvanized)

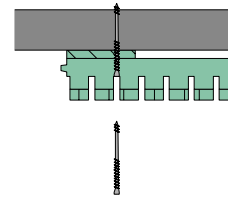

In order for the panel to be in full contact with the substructure, it must be pressed on when screwing, e.g. by means of a clamp. **!**

If a gap is created, the full-thread screw must be unscrewed a little and then screwed in again after pressing on.

Application in indoor aquatic centres

- Lignotrend cross laminated timber panels are approved for the use in the service classes 1 and 2, where wood moisture content does not exceed 20%. **Application in indoor aquatic centres**, for example on the ceiling, typically is completely unproblematic.
- For safety reasons, a maximum moisture content could be defined at 15%, for example. The air's humidity dependent on temperature is limited to reach this goal by adjusting the ventilation system's humidity-control. Wood moisture content resulting as a function of the ambient atmosphere can be retrieved from the diagram below according to Keylwerth.



Fastening in the area of indoor aquatic centres

- Attention must be paid to corrosion-resistant fastener e.g. in case of chlorine-containing air.
- Screwing as shown on page 8. Use screws made of highly corrosion-resistant material that are suitable for the indoor climate (e.g. chlorine-containing air: **Special screws 3,5 x 43, material no. 1.4539** - corrosion resistance class IV, is available from Lignotrend)

Note: not suitable for brine baths!

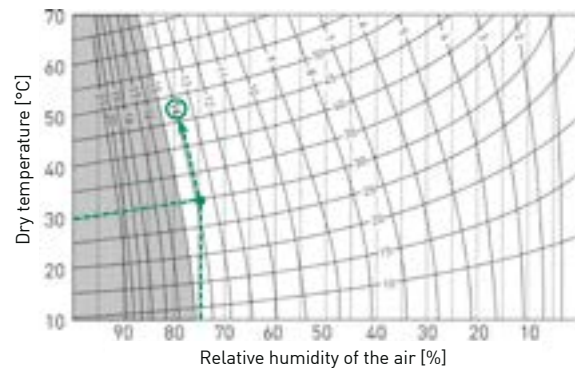

Accessories Termination

In order to achieve a termination visually appealing termination on free edges (e.g. openings, support penetrations), **one-ply-panel material of the same type of wood as the element view** is available from Lignotrend, on request also ready-to-use edge battens in identical surface treatment on request. Commercially available metal profiles can alternatively be used as edge finish.

Proposal 1: Rebated terminal batten

Longitudinal edge

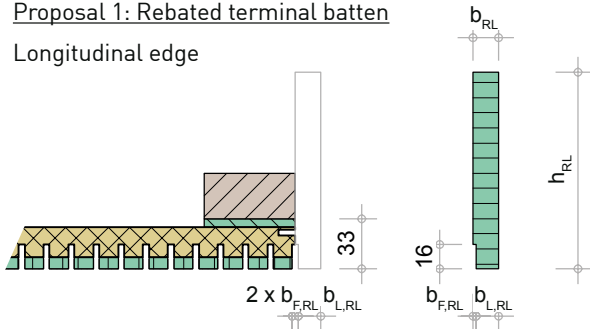

Face edge

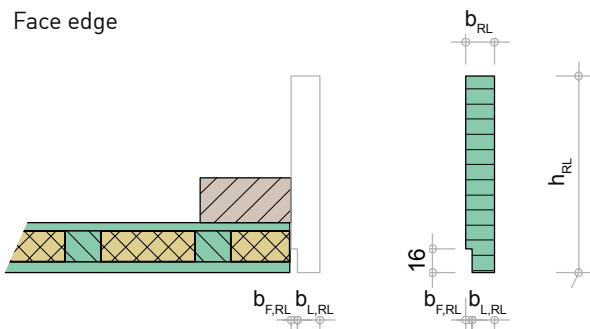

(Representations exemplary for profile _625-12-4)

In this example, the terminal batten is laterally butt-joined. It is fastened e.g. using nails or small clamps.

- Observe the different batten rebate geometry on longitudinal and face edge!
- One will need battens with half and full gap width as rebate width.

Standard terminal battens

Type	Batten height h_{RL}	Batten width b_{RL}	Rebate width $b_{F,RL}$	Visible width of slat $b_{L,RL}$
63-14_2-16	63mm	14 mm	2mm	12mm
63-19_2-16		19 mm	2mm	17mm
63-19_3-16			3mm	16mm
63-19_4-16			4mm	15mm
92-14_2-16	92mm	14 mm	2mm	12mm
92-19_2-16		19 mm	2mm	17mm
92-19_3-16			3mm	16mm
92-19_4-16			4mm	15mm
110-14_2-16	110mm	14 mm	2mm	12mm
110-19_2-16		19 mm	2mm	17mm
110-19_3-16			3mm	16mm
110-19_4-16			4mm	15mm

Edging battens are available in _WTL and _WTL-i wood type. Other wood types as well as other dimensions up to 19 mm thickness on request. Thicker battens are special formats and are produced by laminating two or more battens.

Proposal 2: Rebated terminal batten

Longitudinal edge

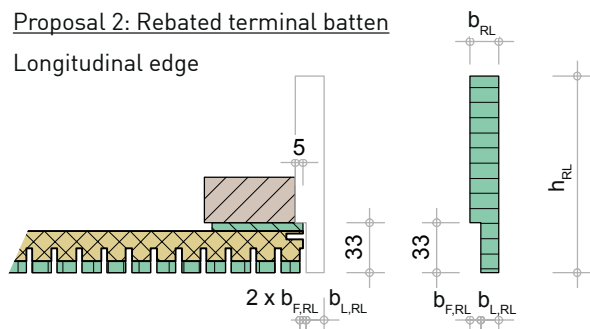

Face edge

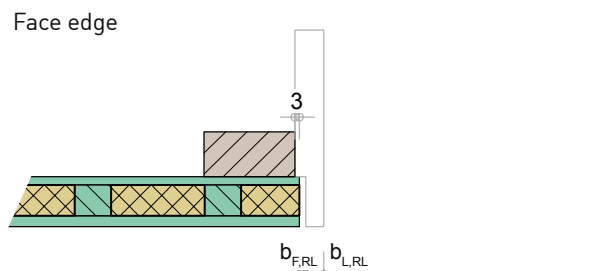

(Representations exemplary for profile _625-12-4)

A planed batten with a precisely defined distance from the element edge is mounted onto the elements' back as a reference edge for the terminal batten.

In this way, the **identical joint and batten width like the elements' surface** can be produced on the termination of the visible face.

Notes:

- An edging strip in a special format is required for this version.
- We recommend arranging the last substructure batten on such edges (not shown) recessed to the last but one ledge of the rear element layer by approx. 20 cm.

Proposal 3: Metal profile

Longitudinal and face edge

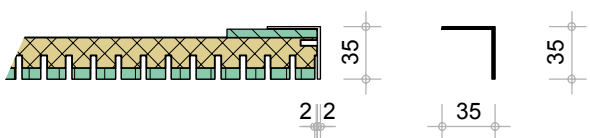

An L-profile is mounted as termination.

Notes:

- The joint visible will become smaller at the frame.
- Only feasible if fixing from above is possible (e.g. with pre-assembled sail).

Accessories

Inspection openings

Frame inspection flap for frequent opening

Pre-assembled, flush inspection flap with hinge and square lock

Suitable only for types 3S_33 and 3G_33! Minimum suspension height: 100 mm!

- Sturdy aluminum frame for filling with panel piece (not included), on request pre-assembly ex factory
- To rest on standard wood substructure in 27 mm thickness
- Installation dimension (great model) 625 mm x 599 mm
- Installation dimension (small model) 625 mm x 355 mm

► [Data sheet installation instructions for inspection openings](#)

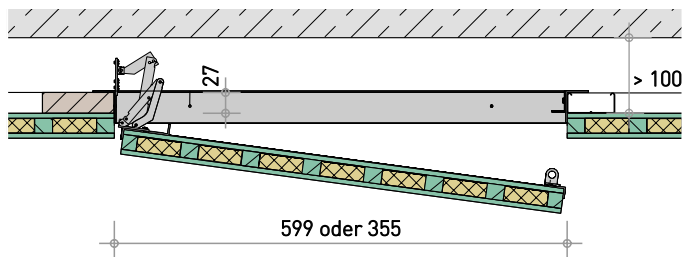
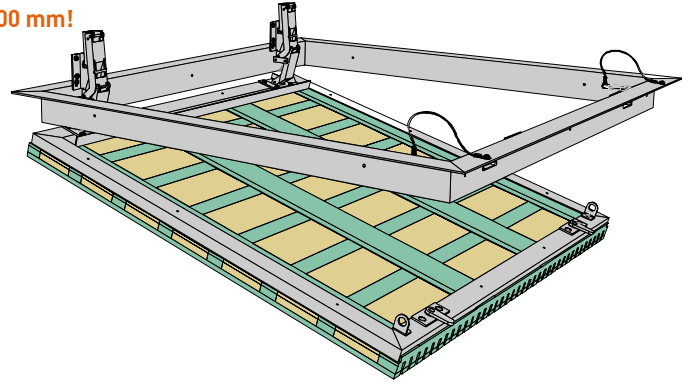

Inspection flap, screwed on, for rare opening

Simple inspection flap, made from standard elements:

- Opening width = element width, opening length arbitrary
- Fit in the inspection flap, consider gap width
- Cut off tongue on one side, opposite wood behind groove
- Provide protection against falling down
- Screw to edge joint

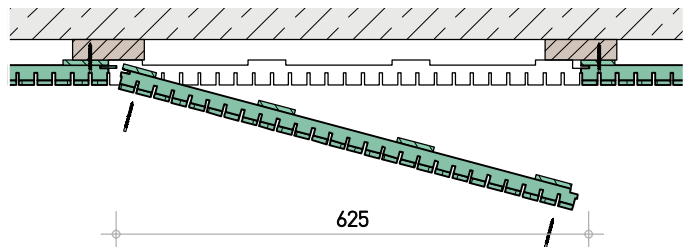

Inspection flap, loosely inserted

Simple inspection flap over element width 625 mm Length l as desired, max. 1 000 mm

Observe minimum suspension height!

- Cut out desired opening to the desired opening size
- Fit in the inspection flap taking into account the gap width intended. Attach two battens to the slats on the panel's back.
- Provide protection against falling down
- If desired, secure with screws in the acoustic gaps.

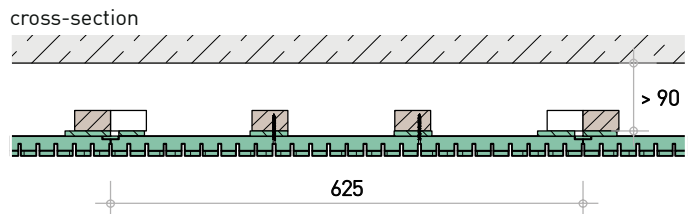

Longitudinal section

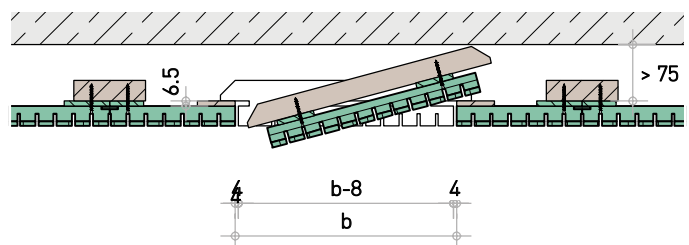
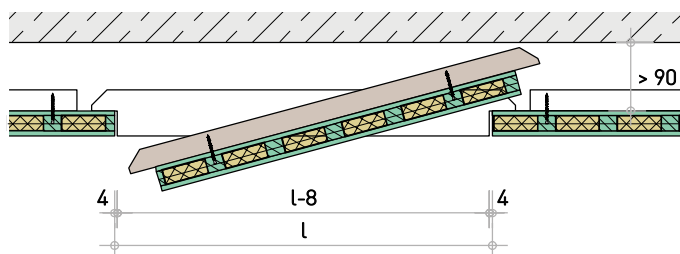

Accessories

LED light strip

LIGNO® LED light strips for subsequent and on-site installation on LIGNO® Acoustic light panels..

The installation is carried out planar in or next to the element joint. Alternatively, the light strips can also be retrofitted to fit the 4 mm joint as a surface installation.

► [Data sheet installation instructions for LED light strip](#)



Flush installation:

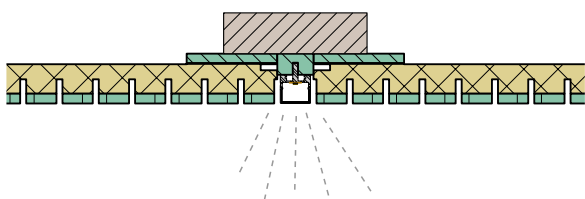

Clip-on installation:

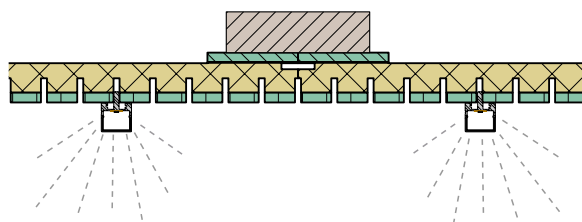

Light strip 20 mm width

Compatible with profile variants [_625-20-4](#) and [_625-12n25-4](#)

- High-quality surface-mounted lamp made of aluminium extrusion profile, coated similar to RAL 9010 incl. end caps, harpoon form 4.2 mm
- LxWxH: approx. **(n x 100 + 15)** x 20 x 27 mm, L_{max} 2915 mm per element
- Diffusers made of white translucent PMMA, flush with profile
- Light source LED, energy efficiency class A+ / A++, degradation L80/b10 connected voltage 24 V; flexible supply cable with 2 x 0.75 mm and Wieland plug up to 2.8 m protection class III; IP 20
- Prepared for on-site connection to converter

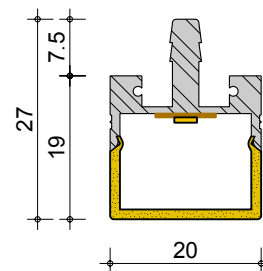

Light strip 28 mm width

Compatible with profile variants [_625-12-4](#), [_625-12n25-4](#) and [_625-22n40-4](#)

- LxWxH: ca. **(n x 100 + 15)** x 28 x 27 mm, L_{max} 2915 mm per element

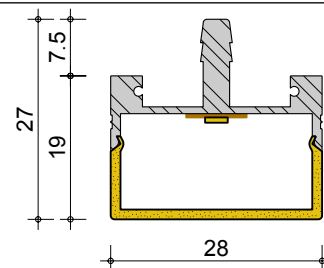

LIGNO® LED-light strip

Luminous intensity in lm / m	Light colour in Kelvin	Connected load in W / m	Dimmability
720	2 400 K ¹ 2 700 K ¹ 3 000 K	8,9	DALI möglich
	4 000 K ¹ 5 000 K ¹ 6 500 K ¹	8,1	
1 200	2 400 K ¹ 2 700 K ¹ 3 000 K	15,0	DALI möglich
	4 000 K ¹ 5 000 K ¹ 6 500 K ¹	13,6	
1 800	2 400 K ¹ 2 700 K ¹ 3 000 K	23,7	DALI möglich
	4 000 K ¹ 5 000 K ¹ 6 500 K ¹	23,8	

Converter for standard LIGNO® LED light strip

DALI	Power in Watts	Voltage in V	Dimensions (LxWxH)
-	50	220-240/24V	242 x 40 x 16 mm
-	75	220-240/24V	242 x 47 x 44 mm
dimmbar	50	220-240/24V	346 x 32 x 22 mm
dimmbar	80	220-240/24V	346 x 32 x 22 mm
dimmbar	160	220-240/24V	346 x 50 x 35 mm

Accessories

Connecting cable with socket and plug (GST08i275T)

¹ Extended delivery time

LIGNO® LED light strips

Calculation

The following table serves as an orientating planning aid based on a sample room calculation –

Room size: 16 m²; degree of reflection, ceiling and wall: 50 %, floor: 20 %..

However, it is not a substitute for a detailed light calculation by an expert.

Requirement lx/m ²	Distance visual task – light source	Required light strip length [m] Luminous intensity 720 lm/m	Required light strip length [m] Luminous intensity 1200 lm/m	Required light strip length [m] Luminous intensity 1800 lm/m
Bedroom 50 lx/m ²	1,2m (high table)	0,13	0,08	0,05
	1,6m (work surface)	0,15	0,10	0,06
	2,5m (floor)	0,19	0,13	0,08
Children's bedroom / living room / hall / stairs / storeroom / basement 100 lx/m ²	1,2m (high table)	0,24	0,15	0,10
	1,6m (work surface)	0,27	0,16	0,13
	2,5m (floor)	0,35	0,20	0,15
Bathroom / kitchen 150 lx/m ²	1,2m (high table)	0,35	0,25	0,15
	1,6m (work surface)	0,40	0,27	0,16
	2,5m (floor)	0,50	0,30	0,22
Office / hobby room 300 lx/m ²	1,2m (high table)	0,69	0,45	0,30
	1,6m (work surface)	0,83	0,50	0,35
	2,5m (floor)	1,05	0,62	0,45
Work surface (desk) 500 lx/m ²	1,2m (high table)	1,25	0,75	0,50
	1,6m (work surface)	1,35	0,83	0,56
	2,5m (floor)	1,80	1,05	0,69

■ recommended ■ only conditionally useful ■ not useful

Example: Office / hobby room with 16 m² floor space

- required luminous intensity approx. 300 lx/m
- Distance from light source 2.5 m

720 lm/m: 1,05 m/m² x 16 m²
= **16,8 m LIGNO® LED light strip**

1 200 lm/m: 0,62 m/m² x 16 m²
= **9,9 m LIGNO® LED light strip**

1 800 lm/m: 0,45 m/m² x 16 m²
= **7,2 m LIGNO® LED light strip**

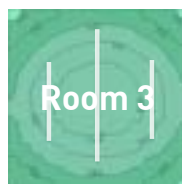
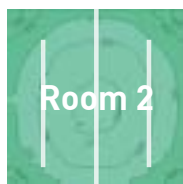
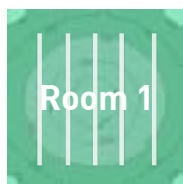

Term	Definition	Unit	Abbreviation
Luminous flux	Measure of the total light power output by a light source in all directions.	Lumen	lm
Luminous intensity	Ratio of luminous flux that strikes a certain area to the size of that area (lm / m ² = lx). The luminous intensity is not bound to an object surface and is not a product property because it is a receiver variable. Illuminance meters are used for measurement.	Lux	lx
Light colour	The colour of a self-illuminating light source. The lower the value, the redder, the higher the value the bluer the light colour. Assignment of the light colour to the colour temperature ranges according to EN 12464-1 warm white (ww) 2700 - 3300K neutral white (nw) 3300 - 5300K daylight white (tw) > 5.300K	Kelvin	K
Connected load	Necessary watts/ metre of light strip. The total length in metres of light strip x and the connected load W/m produce the total output of the light strips and is required for the design of the converter/transformer.	Watt/ metre	W/m
Degree of reflection	The degree of reflection depends on the colour of the surface and describes what percentage of the incident light is reflected back.		
Light yield	Ratio of the emitted luminous flux [lm] to the consumed electrical power P [W].	Lumen/ Watt	lm/W
Useful level	Distance to the useful level = clearance room height - area of the visual task		
Degradation	(e.g. L80 / B10) according to the specified lifetime of the LED, the specified luminous flux output drops to less than 80% in 10% of the diodes that had been intact until then. Therefore, 15 % more light output should be taken into account when planning new systems in order to compensate for the decrease in luminous flux.		
DALI	Digital Addressable Lighting Interface: is a protocol for the control of lighting devices in building automation		

Types 3S_33 / 3G_33 Special applications

Cuttings for grid ceilings

The LIGNO® Acoustic light 3S-33 panels are available pre-cut for the purpose of inserting them into grid ceilings (e.g. from Donn profiles DX 24).

Width	613 mm
Length	613 mm
Weight	9,1 kg/m ² ca. 3,5 kg/panel

Other cuttings up to 625 mm in width on request

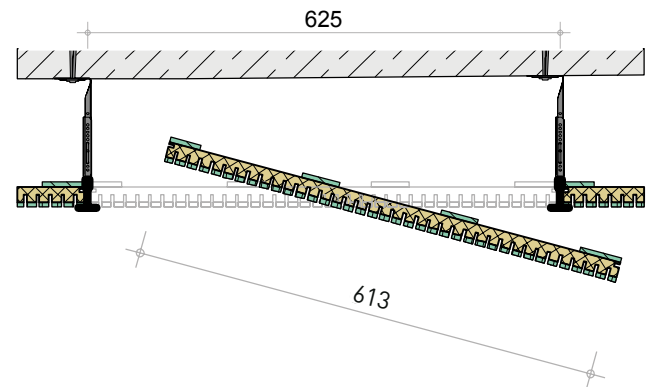

Freely suspended acoustic canopies

Customised canopies on request for targeted, selective interruption of sound reflection. The load-bearing ceiling will not be thermally decoupled (e.g. when the building uses **activation of concrete core**).

The canopy consists of LIGNO® Acoustic light element strips, optionally one light fixture, aluminium edges and appropriate suspension cables and connection material.

Canopy width	on request
Canopy length	on request
Fastening	Cables (state required length when ordering), upper and lower brackets, hooks included

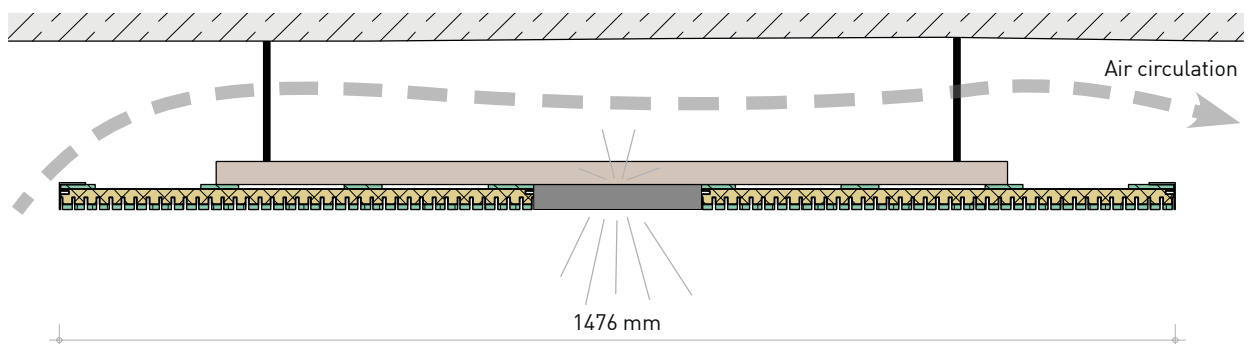

Impact wall

Instead of LIGNO® Acoustic light, the **optimized element type LIGNO® Acoustic Sport** is used for acoustically effective cladding of force-reducing impact walls in sports halls.

See technical details of surface, flammability and tested substructures made of wood and metal in the separate

► [Technical data sheet LIGNO® Acoustic Sport](#).



Acoustic absorption Type 3S_33 with cavity

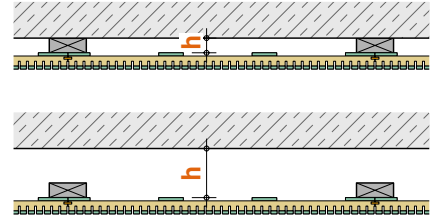

LIGNO® Acoustic light 3S_33_a70g

h = 30 mm

installed in front of 30 mm cavity

Profile	α_w	NRC	SAA	SAK	Form	125 Hz	250 Hz	500 Hz	1 kHz	2 kHz	4 kHz
_625-12-4	0,60	0,75	0,73	C	MH	0,10	0,30	0,75	0,95	0,90	0,75
_625-18-6	0,60	0,75	0,73	C	MH	0,10	0,30	0,75	0,95	0,90	0,70
_625-23-8	0,60	0,75	0,73	C	MH	0,10	0,30	0,75	0,95	0,90	0,75
_625-20-4	0,65	0,70	0,72	C	M	0,10	0,35	0,80	0,95	0,80	0,60
_625-12n25-4	0,65	0,75	0,74	C	M	0,15	0,35	0,75	0,95	0,85	0,70
_625-18n38-6	0,65	0,75	0,73	C	M	0,10	0,35	0,80	0,95	0,80	0,65

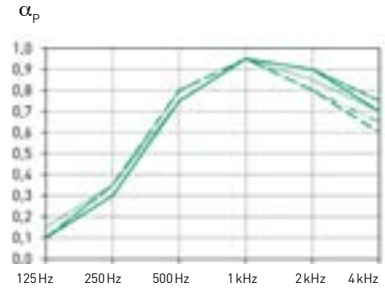

LIGNO® Acoustic light 3S_33_a70g

h = 100 mm

installed in front of 100 mm cavity

Profile	α_w	NRC	SAA	SAK	Form	125 Hz	250 Hz	500 Hz	1 kHz	2 kHz	4 kHz
_625-12-4	0,80	0,80	0,81	B		0,25	0,60	0,80	0,85	0,90	0,70
_625-18-6	0,85	0,80	0,80	B		0,25	0,65	0,80	0,90	0,90	0,70
_625-23-8	0,80	0,80	0,79	B		0,30	0,60	0,80	0,90	0,90	0,70
_625-20-4	0,80	0,75	0,77	B		0,30	0,60	0,80	0,85	0,80	0,60
_625-12n25-4	0,80	0,80	0,80	B		0,30	0,65	0,80	0,90	0,85	0,65
_625-18n38-6	0,80	0,80	0,79	B		0,25	0,65	0,85	0,85	0,80	0,60

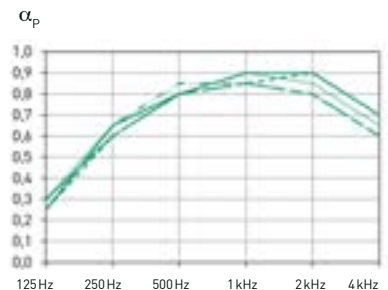

LIGNO® Acoustic light 3S_33_a70g

h = 150 mm

installed in front of 150 mm cavity

Profile	α_w	NRC	SAA	SAK	Form	125 Hz	250 Hz	500 Hz	1 kHz	2 kHz	4 kHz
_625-12-4	0,75	0,70	0,72	C		0,45	0,60	0,75	0,80	0,75	0,65
_625-18-6	0,75	0,75	0,74	C		0,45	0,65	0,75	0,80	0,75	0,65
_625-23-8	0,75	0,75	0,73	C		0,45	0,60	0,75	0,80	0,75	0,65
_625-20-4	0,70	0,70	0,71	C		0,45	0,60	0,75	0,80	0,65	0,55
_625-12n25-4	0,70	0,70	0,71	C		0,50	0,55	0,70	0,90	0,70	0,60
_625-18n38-6	0,70	0,75	0,73	C		0,45	0,65	0,80	0,80	0,65	0,55

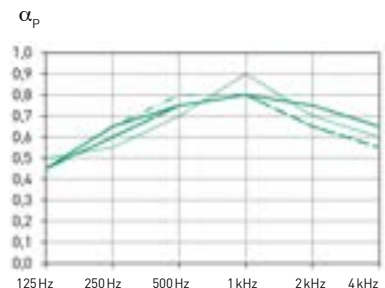

LIGNO® Acoustic light 3S_33_a70g

h = 200 mm

installed in front of 200 mm cavity

Profile	α_w	NRC	SAA	SAK	Form	125 Hz	250 Hz	500 Hz	1 kHz	2 kHz	4 kHz
_625-12-4	0,80	0,80	0,80	B		0,40	0,75	0,80	0,75	0,90	0,70
_625-18-6	0,80	0,80	0,80	B		0,40	0,75	0,80	0,80	0,90	0,60
_625-23-8	0,80	0,80	0,80	B		0,40	0,75	0,80	0,75	0,90	0,65
_625-20-4	0,75	0,80	0,78	B		0,50	0,70	0,75	0,85	0,80	0,55
_625-12n25-4	0,75	0,80	0,80	C		0,45	0,70	0,75	0,85	0,85	0,60
_625-18n38-6	0,75	0,80	0,76	C		0,45	0,70	0,80	0,85	0,80	0,55

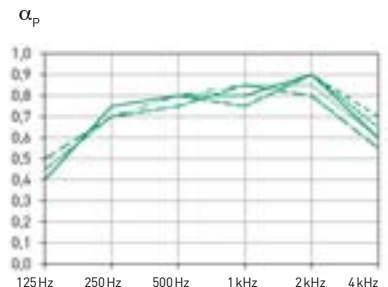

LIGNO® Acoustic light 3S_33_a70g

h = 400 mm

installed in front of 400 mm cavity

Profile	α_w	NRC	SAA	SAK	Form	125 Hz	250 Hz	500 Hz	1 kHz	2 kHz	4 kHz
_625-12-4	0,80	0,80	0,81	B		0,60	0,70	0,70	0,90	0,95	0,70
_625-18-6	0,75	0,80	0,81	C		0,55	0,70	0,70	0,90	0,90	0,65
_625-23-8	0,80	0,80	0,81	B		0,60	0,70	0,70	0,85	0,95	0,75
_625-20-4	0,75	0,81	0,80	C		0,60	0,75	0,75	0,90	0,85	0,55
_625-12n25-4	0,75	0,80	0,79	C		0,65	0,65	0,65	0,95	0,90	0,65
_625-18n38-6	0,75	0,80	0,81	C		0,60	0,75	0,75	0,90	0,85	0,60



Acoustic absorption Typ 3G_33 with cavity

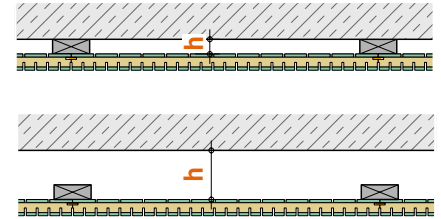

LIGNO® Acoustic light 3G_33_a70g

h = 30 mm

installed in front of 30 mm cavity

Profile	α_w	NRC	SAA	SAK	Form	125 Hz	250 Hz	500 Hz	1 kHz	2 kHz	4 kHz
_625-12-4	0,60	0,70	0,68	C	MH	0,10	0,35	0,60	0,85	0,90	0,70
_625-18-6	0,60	0,65	0,66	C	MH	0,10	0,30	0,60	0,85	0,90	0,70
_625-23-8	0,60	0,70	0,68	C	MH	0,10	0,35	0,60	0,85	0,90	0,70
_625-20-4	0,65	0,70	0,70	C	M	0,20	0,40	0,70	0,90	0,80	0,50
_625-12n25-4	0,60	0,70	0,68	C	MH	0,10	0,35	0,60	0,95	0,85	0,60
_625-22n40-4	0,60	0,65	0,67	C	M	0,15	0,40	0,70	0,90	0,70	0,45
_625-18n38-6	0,60	0,70	0,69	C	MH	0,10	0,35	0,60	0,85	0,95	0,85

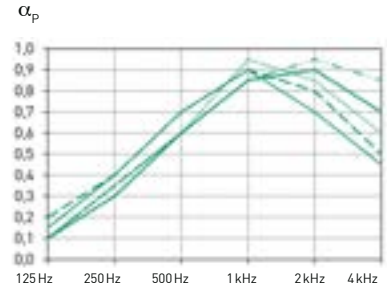

LIGNO® Acoustic light 3G_33_a70g

h = 100 mm

installed in front of 100 mm cavity

Profile	α_w	NRC	SAA	SAK	Form	125 Hz	250 Hz	500 Hz	1 kHz	2 kHz	4 kHz
_625-12-4	0,70	0,70	0,70	C		0,25	0,50	0,65	0,80	0,90	0,70
_625-18-6	0,65	0,70	0,68	C	H	0,25	0,45	0,60	0,80	0,90	0,70
_625-23-8	0,70	0,70	0,69	C		0,20	0,50	0,60	0,80	0,90	0,70
_625-20-4	0,65	0,70	0,69	C		0,30	0,45	0,65	0,85	0,80	0,50
_625-12n25-4	0,70	0,70	0,70	C		0,25	0,50	0,60	0,85	0,85	0,60
_625-22n40-6	0,65	0,70	0,67	C		0,25	0,45	0,65	0,85	0,70	0,50
_625-18n38-6	0,70	0,70	0,70	C		0,25	0,50	0,60	0,85	0,85	0,60

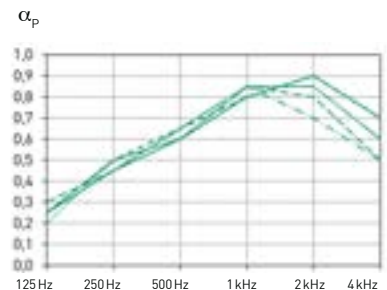

LIGNO® Acoustic light 3G_33_a70g

h = 150 mm

installed in front of 150 mm cavity

Profile	α_w	NRC	SAA	SAK	Form	125 Hz	250 Hz	500 Hz	1 kHz	2 kHz	4 kHz
_625-12-4	0,70	0,70	0,70	C		0,30	0,50	0,60	0,80	0,90	0,70
_625-18-6	0,70	0,70	0,70	C		0,30	0,50	0,60	0,80	0,90	0,70
_625-23-8	0,70	0,70	0,70	C		0,30	0,50	0,60	0,80	0,90	0,70
_625-20-4	0,70	0,70	0,70	C		0,30	0,45	0,60	0,85	0,80	0,55
_625-12n25-4	0,70	0,70	0,70	C		0,30	0,50	0,60	0,80	0,90	0,70
_625-18n38-6	0,70	0,70	0,70	C		0,30	0,50	0,60	0,80	0,90	0,70

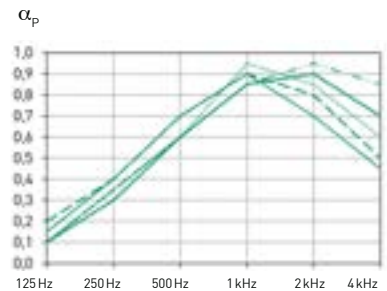

LIGNO® Acoustic light 3G_33_a70g

h = 200 mm

installed in front of 200 mm cavity

Profile	α_w	NRC	SAA	SAK	Form	125 Hz	250 Hz	500 Hz	1 kHz	2 kHz	4 kHz
_625-12-4	0,70	0,70	0,70	C		0,40	0,50	0,60	0,80	0,90	0,70
_625-18-6	0,70	0,70	0,71	C		0,40	0,55	0,60	0,80	0,90	0,70
_625-23-8	0,70	0,70	0,70	C		0,40	0,50	0,65	0,80	0,90	0,70
_625-20-4	0,60	0,65	0,66	C	M	0,30	0,4	0,55	0,85	0,80	0,60
_625-12n25-4	0,70	0,70	0,70	C	H	0,40	0,50	0,65	0,70	0,95	0,80
_625-22n40-4	0,65	0,65	0,67	C		0,35	0,45	0,60	0,85	0,70	0,50
_625-18n38-6	0,70	0,70	0,70	C		0,40	0,55	0,65	0,80	0,80	0,60

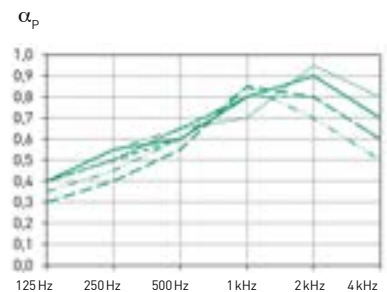

**ONLINE-
CALCULATION**

*Predict the effect on
acoustic quality for
various room usages:*

► [www.lignotrend.com/
acoustic-calculator](http://www.lignotrend.com/acoustic-calculator)

Acoustic absorption Typ 3S_33 with extra absorber (hemp)

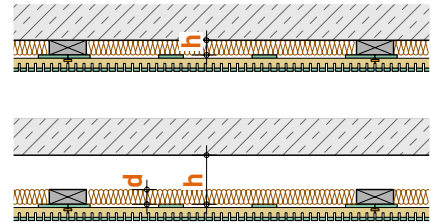

LIGNO® Acoustic light 3S_33_a70g

installed in front of 30 mm cavity, backed with 30 mm hemp

h = 30 mm
d = 30 mm

Profile	α_w	NRC	SAA	SAK	Form	125 Hz	250 Hz	500 Hz	1 kHz	2 kHz	4 kHz
_625-12-4	0,85	0,85	0,83	B		0,20	0,55	0,85	0,95	0,90	0,75
_625-18-6	0,80	0,80	0,78	B		0,25	0,55	0,75	0,90	0,90	0,80
_625-23-8	0,85	0,85	0,84	B		0,20	0,55	0,90	0,95	0,95	0,75
_625-20-4	0,75	0,80	0,80	C		0,20	0,55	0,90	0,95	0,80	0,60
_625-12n25-4	0,80	0,80	0,81	B		0,25	0,55	0,85	0,95	0,90	0,65
_625-18n38-6	0,80	0,80	0,80	B		0,20	0,55	0,90	0,95	0,85	0,65

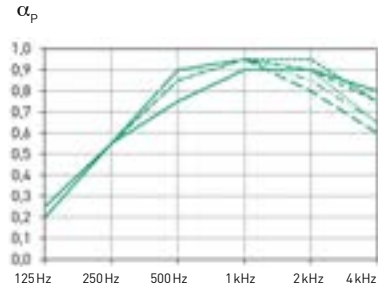

LIGNO® Acoustic light 3S_33_a70g

installed in front of 100 mm cavity, backed with 30 mm hemp

h = 100 mm
d = 30 mm

Profile	α_w	NRC	SAA	SAK	Form	125 Hz	250 Hz	500 Hz	1 kHz	2 kHz	4 kHz
_625-12-4	0,85	0,85	0,83	B		0,40	0,65	0,85	0,90	0,90	0,75
_625-18-6	0,80	0,80	0,78	B		0,40	0,65	0,70	0,80	0,95	0,80
_625-23-8	0,80	0,80	0,78	B		0,40	0,70	0,85	0,90	0,95	0,70
_625-20-4	0,85	0,85	0,84	B		0,40	0,70	0,80	0,85	1,00	0,90
_625-12n25-4	0,80	0,80	0,82	B		0,40	0,65	0,80	0,90	0,90	0,65
_625-18n38-6	0,80	0,80	0,81	B		0,40	0,65	0,85	0,85	0,85	0,60

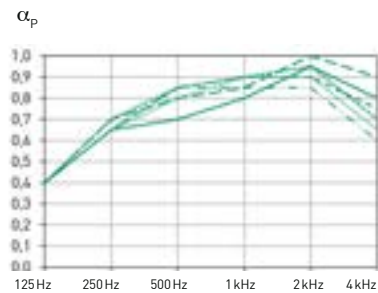

LIGNO® Acoustic light 3S_33_a70g

installed in front of 150 mm cavity, backed with 30 mm hemp

h = 150 mm
d = 30 mm

Profile	α_w	NRC	SAA	SAK	Form	125 Hz	250 Hz	500 Hz	1 kHz	2 kHz	4 kHz
_625-12-4	0,80	0,75	0,75	B		0,55	0,65	0,75	0,80	0,75	0,70
_625-18-6	0,75	0,70	0,70	C		0,55	0,65	0,65	0,75	0,75	0,70
_625-23-8	0,80	0,75	0,77	B		0,50	0,65	0,80	0,85	0,80	0,65
_625-20-4	0,65	0,75	0,73	C		0,50	0,65	0,80	0,85	0,65	0,50
_625-12n25-4	0,75	0,75	0,74	C		0,55	0,65	0,75	0,85	0,75	0,60
_625-18n38-6	0,70	0,75	0,73	C		0,50	0,65	0,80	0,80	0,70	0,55

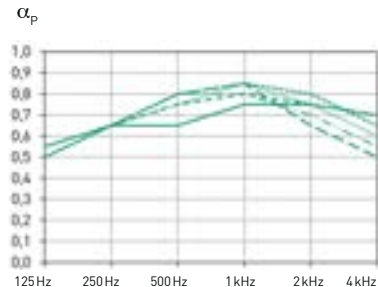

LIGNO® Acoustic light 3S_33_a70g

installed in front of 200 mm cavity, backed with 30 mm hemp

h = 200 mm
d = 30 mm

Profile	α_w	NRC	SAA	SAK	Form	125 Hz	250 Hz	500 Hz	1 kHz	2 kHz	4 kHz
_625-12-4	0,80	0,85	0,83	B		0,55	0,80	0,75	0,85	0,90	0,70
_625-18-6	0,75	0,80	0,78	C		0,55	0,75	0,65	0,80	0,90	0,75
_625-23-8	0,80	0,85	0,84	B		0,50	0,80	0,75	0,90	0,95	0,65
_625-20-4	0,75	0,80	0,80	C	L	0,55	0,80	0,75	0,90	0,80	0,55
_625-12n25-4	0,80	0,80	0,80	B		0,50	0,70	0,75	0,90	0,85	0,65
_625-18n38-6	0,75	0,80	0,76	C		0,50	0,75	0,75	0,85	0,85	0,55



Acoustic absorption Typ 3S_33 with extra absorber (fleece) low absorbing

LIGNO® Acoustic light 3S_33_a70g

installed in front of 100 mm cavity, backed with 50 mm PE-fleece

h = 100 mm
d = 50 mm

Profile	α_w	NRC	SAA	SAK	Form	125 Hz	250 Hz	500 Hz	1 kHz	2 kHz	4 kHz
_625-12-4	0,85	0,85	0,85	B		0,55	0,75	0,80	0,90	0,95	0,70
_625-18-6	0,80	0,80	0,80	B		0,55	0,75	0,70	0,80	0,95	0,75
_625-23-8	0,85	0,85	0,84	B		0,55	0,75	0,80	0,90	0,90	0,75
_625-20-4	0,80	0,85	0,84	B		0,55	0,80	0,80	0,90	0,85	0,60
_625-12n25-4	0,80	0,85	0,84	B		0,55	0,75	0,75	0,90	0,90	0,65
_625-18n38-6	0,80	0,85	0,83	B		0,50	0,75	0,80	0,90	0,85	0,60

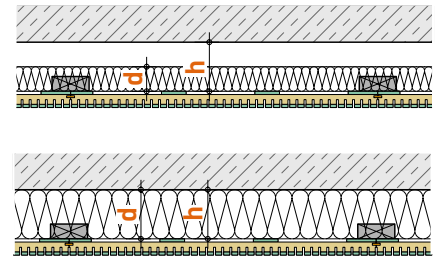

LIGNO® Acoustic light 3S_33_a70g

installed in front of 100 mm cavity, backed with 100 mm PE-fleece

h = 100 mm
d = 100 mm

Profile	α_w	NRC	SAA	SAK	Form	125 Hz	250 Hz	500 Hz	1 kHz	2 kHz	4 kHz
_625-12-4	0,85	0,85	0,83	B		0,70	0,75	0,80	0,90	0,95	0,75
_625-18-6	0,80	0,80	0,78	C		0,75	0,70	0,65	0,80	0,95	0,80
_625-23-8	0,85	0,80	0,82	B		0,75	0,70	0,75	0,90	0,90	0,75
_625-20-4	0,80	0,80	0,82	B		0,75	0,75	0,80	0,90	0,85	0,60
_625-12n25-4	0,80	0,80	0,82	B		0,70	0,75	0,75	0,90	0,90	0,65
_625-18n38-6	0,80	0,80	0,81	B		0,70	0,70	0,80	0,85	0,85	0,65

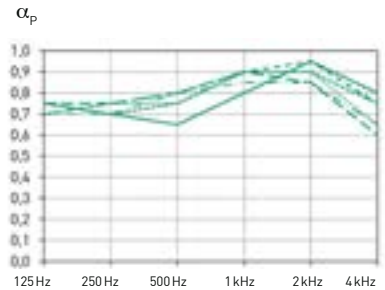

Low absorbing

LIGNO® Acoustic light 3S_33_a10g low absorbing variant

installed in front of 30 mm cavity

h = 30 mm

Profile	α_w	NRC	SAA	SAK	Form	125 Hz	250 Hz	500 Hz	1 kHz	2 kHz	4 kHz
_625-12-4	0,30	0,30	0,31	D	H	0,20	0,25	0,25	0,30	0,45	0,65
_625-18-6	0,30	0,30	0,30	D	H	0,15	0,25	0,25	0,30	0,40	0,60
_625-23-8	0,30	0,25	0,27	D	H	0,20	0,25	0,25	0,25	0,35	0,55
_625-20-4	0,30	0,30	0,31	D	H	0,20	0,25	0,25	0,30	0,45	0,70
_625-12n25-4	0,35	0,30	0,33	D	H	0,20	0,25	0,25	0,35	0,45	0,70
_625-18n38-6	0,25	0,25	0,26	E	H	0,15	0,20	0,20	0,25	0,35	0,60

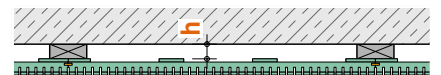

Directly installed

LIGNO® Acoustic light 3S_33_a70g

installed without cavity, only on level timber construction

h = 0 mm
(ca. 7 mm cavity in the element)

Profile	α_w	NRC	SAA	SAK	Form	125 Hz	250 Hz	500 Hz	1 kHz	2 kHz	4 kHz
_625-12-4	0,40	0,55	0,57	D	MH	0,05	0,10	0,40	0,90	0,90	0,75
_625-18-6	0,45	0,65	0,64	D	MH	0,05	0,15	0,55	0,95	0,90	0,75
_625-23-8	0,40	0,55	0,57	D	MH	0,05	0,10	0,40	0,90	0,90	0,70
_625-20-4	0,40	0,55	0,56	D	MH	0,05	0,10	0,45	0,95	0,70	0,55
_625-12n25-4	0,40	0,60	0,60	D	MH	0,05	0,10	0,50	0,95	0,85	0,65
_625-18n38-6	0,40	0,60	0,60	D	MH	0,05	0,10	0,50	0,95	0,80	0,60

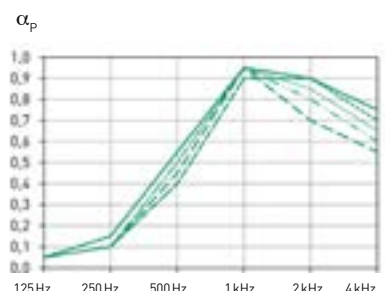
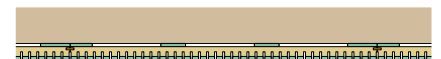

Acoustic absorption Typ 3S_33 with extra absorber (mineral wool)

LIGNO® Acoustic light 3S_33_a70g

installed in front of 30 mm cavity, backed with 30 mm mineral wool

h = 30 mm
d = 30 mm

Profile	α_w	NRC	SAA	SAK	Form	125 Hz	250 Hz	500 Hz	1 kHz	2 kHz	4 kHz
_625-12-4	0,90	0,85	0,85	A		0,25	0,70	0,85	0,95	0,95	0,75
_625-18-6	0,80	0,80	0,80	B		0,30	0,70	0,70	0,85	0,95	0,80
_625-23-8	0,90	0,85	0,86	A		0,25	0,70	0,85	0,95	0,95	0,75
_625-20-4	0,80	0,85	0,83	B		0,25	0,70	0,85	0,95	0,80	0,60
_625-12n25-4	0,80	0,85	0,84	B		0,25	0,70	0,80	0,95	0,90	0,65
_625-18n38-6	0,85	0,85	0,83	B		0,25	0,70	0,85	0,95	0,85	0,65

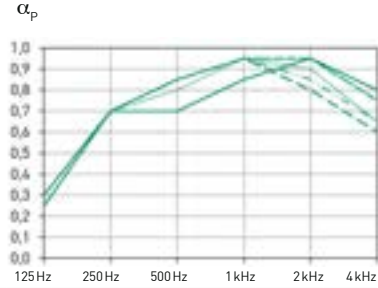
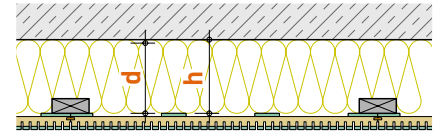
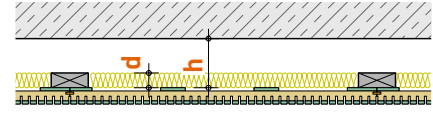

LIGNO® Acoustic light 3S_33_a70g

installed in front of 100 mm cavity, backed with 30 mm mineral wool

h = 100 mm
d = 30 mm

Profile	α_w	NRC	SAA	SAK	Form	125 Hz	250 Hz	500 Hz	1 kHz	2 kHz	4 kHz
_625-12-4	0,85	0,85	0,83	B		0,40	0,70	0,80	0,90	0,95	0,75
_625-18-6	0,80	0,80	0,78	B		0,40	0,70	0,70	0,80	0,95	0,80
_625-23-8	0,85	0,85	0,85	B		0,40	0,70	0,80	0,90	0,95	0,75
_625-20-4	0,90	0,85	0,84	A		0,40	0,70	0,80	0,90	1,00	0,95
_625-12n25-4	0,90	0,85	0,84	A		0,40	0,70	0,85	0,85	0,95	0,85
_625-18n38-6	0,90	0,85	0,85	A		0,40	0,70	0,80	0,90	1,00	0,90

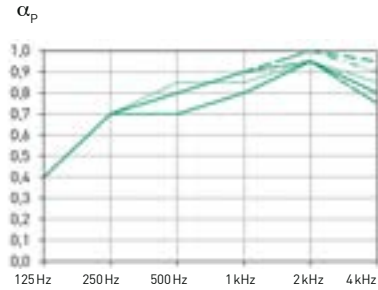

LIGNO® Acoustic light 3S_33_a70g

installed in front of 150 mm cavity, backed with 30 mm mineral wool

h = 150 mm
d = 30 mm

Profile	α_w	NRC	SAA	SAK	Form	125 Hz	250 Hz	500 Hz	1 kHz	2 kHz	4 kHz
_625-12-4	0,80	0,85	0,84	B	L	0,60	0,70	0,75	0,80	0,80	0,70
_625-18-6	0,80	0,85	0,84	B	L	0,60	0,70	0,75	0,75	0,80	0,80
_625-23-8	0,80	0,85	0,84	B	L	0,55	0,70	0,75	0,80	0,80	0,75
_625-20-4	0,80	0,85	0,84	B	L	0,55	0,70	0,70	0,75	0,90	0,90
_625-12n25-4	0,80	0,80	0,82	B	L	0,55	0,65	0,75	0,80	0,80	0,80
_625-18n38-6	0,75	0,75	0,75	C		0,55	0,70	0,75	0,80	0,70	0,80

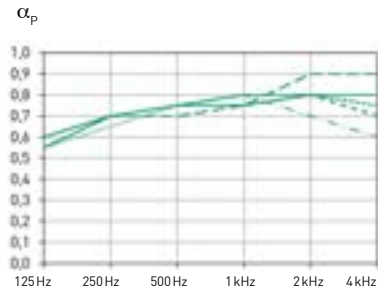

LIGNO® Acoustic light 3S_33_a70g

installed in front of 200 mm cavity, backed with 30 mm mineral wool

h = 200 mm
d = 30 mm

Profile	α_w	NRC	SAA	SAK	Form	125 Hz	250 Hz	500 Hz	1 kHz	2 kHz	4 kHz
_625-12-4	0,80	0,85	0,85	B	L	0,50	0,85	0,80	0,75	0,95	0,75
_625-18-6	0,85	0,85	0,85	B		0,55	0,85	0,85	0,75	0,95	0,80
_625-23-8	0,85	0,85	0,83	B		0,50	0,85	0,85	0,80	0,95	0,70
_625-20-4	0,75	0,85	0,85	C	L	0,50	0,85	0,85	0,75	0,80	0,55
_625-12n25-4	0,80	0,85	0,83	B	L	0,55	0,85	0,80	0,80	0,90	0,65
_625-18n38-6	0,75	0,85	0,83	C	L	0,50	0,85	0,80	0,75	0,85	0,70

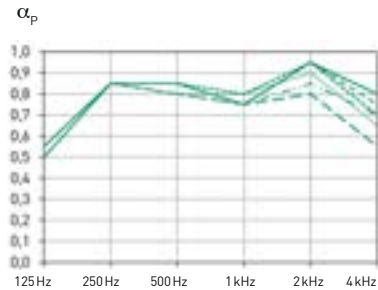

LIGNO® Acoustic light 3S_33_a70g

installed in front of 150 mm cavity, backed with 140 mm rockwool

h = 150 mm
d = 140 mm

Profile	α_w	NRC	SAA	SAK	Form	125 Hz	250 Hz	500 Hz	1 kHz	2 kHz	4 kHz
_625-12-4	0,85	0,85	0,85	B		0,70	0,75	0,80	0,90	0,95	0,75
_625-18-6	0,75	0,80	0,80	C		0,75	0,75	0,65	0,85	0,95	0,75
_625-23-8	0,85	0,85	0,86	B		0,70	0,75	0,80	0,95	0,95	0,70
_625-20-4	0,75	0,85	0,83	B		0,70	0,75	0,80	0,95	0,85	0,55
_625-12n25-4	0,80	0,85	0,84	B		0,70	0,75	0,75	0,95	0,95	0,65
_625-18n38-6	0,80	0,85	0,83	B		0,70	0,75	0,80	0,90	0,90	0,60

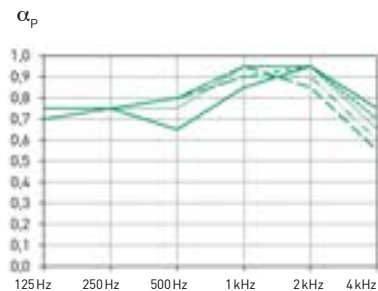

Acoustic absorption Typ 3G_33 with extra absorber (mineral wool)

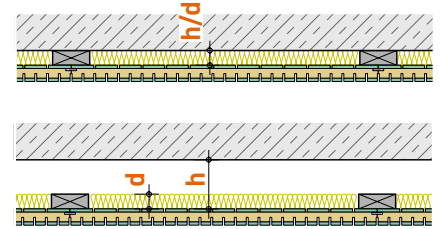

LIGNO® Acoustic light 3G_33_a70g

installed in front of 30 mm cavity, backed with 30 mm mineral wool

h = 30 mm
d = 30 mm

Profile	α_w	NRC	SAA	SAK	Form	125 Hz	250 Hz	500 Hz	1 kHz	2 kHz	4 kHz
_625-12-4	0,75	0,75	0,74	C		0,30	0,55	0,70	0,85	0,90	0,70
_625-18-6	0,80	0,75	0,76	B		0,30	0,60	0,70	0,85	0,90	0,70
_625-23-8	0,75	0,75	0,75	C		0,30	0,55	0,70	0,85	0,90	0,70
_625-20-4	0,65	0,70	0,72	C	M	0,35	0,50	0,65	0,90	0,80	0,50
_625-12n25-4	0,75	0,75	0,74	C		0,25	0,60	0,70	0,75	0,95	0,80
_625-22n40-4	0,65	0,70	0,70	C	M	0,30	0,55	0,65	0,90	0,70	0,45
_625-18n38-6	0,75	0,75	0,75	C		0,30	0,60	0,75	0,85	0,80	0,60

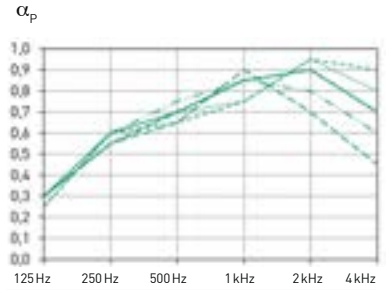

LIGNO® Acoustic light 3G_33_a70g

installed in front of 100 mm cavity, backed with 30 mm mineral wool

h = 100 mm
d = 30 mm

Profile	α_w	NRC	SAA	SAK	Form	125 Hz	250 Hz	500 Hz	1 kHz	2 kHz	4 kHz
_625-12-4	0,70	0,70	0,71	C		0,40	0,50	0,60	0,80	0,90	0,70
_625-18-6	0,80	0,75	0,76	B		0,40	0,55	0,75	0,85	0,90	0,70
_625-23-8	0,70	0,70	0,70	C		0,40	0,50	0,60	0,80	0,90	0,75
_625-20-4	0,60	0,70	0,70	C	M	0,45	0,50	0,60	0,90	0,80	0,45
_625-12n25-4	0,75	0,75	0,73	C		0,40	0,55	0,65	0,85	0,85	0,65
_625-22n40-4	0,60	0,70	0,67	C	M	0,40	0,50	0,60	0,85	0,70	0,45
_625-18n38-6	0,70	0,70	0,69	C		0,40	0,50	0,60	0,80	0,85	0,60

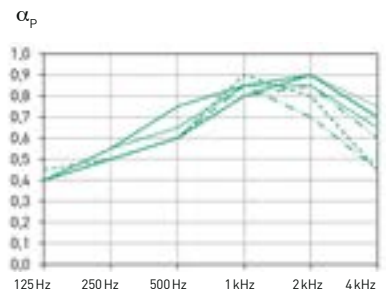

LIGNO® Acoustic light 3G_33_a70g

installed in front of 150 mm cavity, backed with 30 mm mineral wool

h = 150 mm
d = 30 mm

Profile	α_w	NRC	SAA	SAK	Form	125 Hz	250 Hz	500 Hz	1 kHz	2 kHz	4 kHz
_625-12-4	0,70	0,70	0,71	C		0,50	0,55	0,60	0,80	0,90	0,75
_625-18-6	0,80	0,80	0,78	B		0,45	0,55	0,75	0,85	0,90	0,70
_625-23-8	0,70	0,70	0,70	C		0,50	0,55	0,60	0,80	0,90	0,75
_625-20-4	0,70	0,70	0,70	C		0,55	0,55	0,60	0,85	0,85	0,55
_625-12n25-4	0,75	0,75	0,73	C		0,50	0,55	0,65	0,80	0,90	0,75
_625-18n38-6	0,70	0,70	0,69	C		0,40	0,50	0,60	0,80	0,90	0,70



LIGNO® Acoustic light 3G_33_a70g

installed in front of 200 mm cavity, backed with 30 mm mineral wool

h = 200 mm
d = 30 mm

Profile	α_w	NRC	SAA	SAK	Form	125 Hz	250 Hz	500 Hz	1 kHz	2 kHz	4 kHz
_625-12-4	0,70	0,70	0,71	C		0,60	0,55	0,60	0,80	0,90	0,75
_625-18-6	0,80	0,80	0,78	B		0,55	0,60	0,75	0,85	0,90	0,70
_625-23-8	0,70	0,70	0,70	C		0,60	0,55	0,60	0,80	0,85	0,75
_625-20-4	0,70	0,70	0,71	C		0,60	0,55	0,60	0,80	0,90	0,65
_625-12n25-4	0,75	0,75	0,73	C		0,55	0,60	0,65	0,75	0,90	0,80
_625-18n38-6	0,70	0,70	0,72	C	H	0,40	0,55	0,60	0,80	0,95	0,85

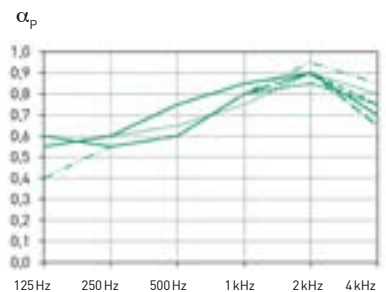

ONLINE-CALCULATION

Predict the effect on acoustic quality for various room usages:

► www.lignotrend.com/acoustic-calculator

Acoustic absorption Canopies

Full essays of the laboratory tests ► www.lignotrend.com
on demand also available printed.

LIGNO® Acoustic canopy

several suspension heights,
measured as a group of 6 sails
with a 100 mm gap

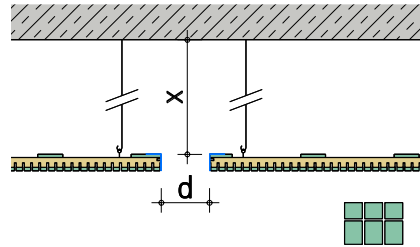

Profile	Suspension	α_w	NRC	SAK	125 Hz	250 Hz	500 Hz	1 kHz	2 kHz	4 kHz
_625-12-4	x = 200	0,70	0,70	C	0,20	0,50	0,65	0,75	0,85	0,75
	x = 400	0,60	0,65	C	0,15	0,50	0,60	0,80	0,95	0,90
	x = 800	0,70	0,70	C	0,15	0,40	0,60	0,90	1,00	1,00

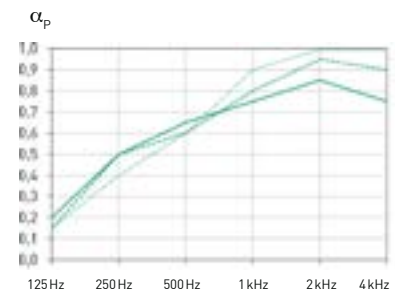

LIGNO® Acoustic canopy

measured as a group of 6 sails
with a 300 mm gap

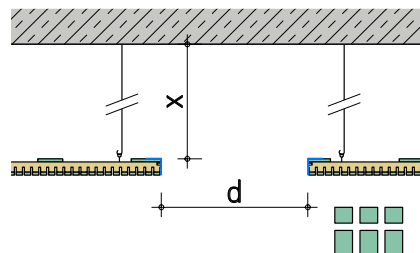

Profile	Suspension	α_w	NRC	SAK	125 Hz	250 Hz	500 Hz	1 kHz	2 kHz	4 kHz
_625-18-6	x = 200	0,60	0,70	C	0,15	0,45	0,60	0,65	0,80	0,70

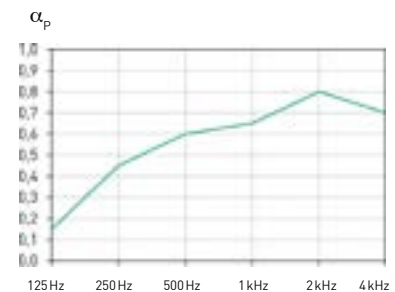

Overview element weights

	Type	3S_33	3G_33	3S_39/40
Width covered		625	625	625 mm
Length covered	Standard	2940	2940	2940 mm
Weight	Softwood surface, all profiles except _625-20-4	9,2 [16,8]	11,6 [21,3]	12,9 [23,5] kg/m ² (kg/element)
Excess weight	Oak surface _EI	+1,1 [+2,0]	+1,1 [+2,0]	+1,1 [+2,0] kg/m ² (kg/element)
	Profile _625-20-4	+0,5 [+0,9]	+0,5 [+0,9]	- kg/m ² (kg/element)
	Absorber _a10g instead of _a70g / _a50g	+2,7 [+4,9]	+2,7 [+4,9]	+2,8 [+5,1] kg/m ² (kg/element)
	Absorber _a50h instead of _a50g	-	-	- kg/m ² (kg/element)
	Surface _B-s2-d0 /B1	+0,4 [+0,8]	+0,4 [+0,8]	+1,0 [+1,9] kg/m ² (kg/element)

(Values in brackets indicate the weight per element in standard length)

Check list

Material for panelling	
LIGNO® Acoustic light acoustic panels	Allow for a reserve in quantity for offcuts.
Insulating mats	If required, for backing (e.g. hemp, supplier: Lignotrend)
UV protection	If required, for curing spots that were ground on the building site, supplier: Lignotrend.
Material for simple batten substructure	
Battens	Type 3S-33: for the best result: stripes of laminated veneer lumber 27/95/2500 (supplier: Lignotrend), e= 625 mm, alternative: timber battens, for example 30/100 Typ 3S-62: timber battens, for example 40/60, e= 800 mm
Dowels and fasteners	Select according to base
Clamps	For fastening the elements in the acoustic joints ► page 14 For fire retardant substructure: Knoll clamps type A, material no. 1.4301
Screws see also ► page 14 - 18	Instead of clamps, for fastening the elements in the acoustic joints (supplier: Lignotrend) - special fully-thread drilling screws 3,5 x 40 (V4A) - special fully-thread drilling screws 3,5 x 43, material no. 1.4539 - special tapping screws, self-tapping 3.5 x 48, galvanized
Battens for lining	For fastening the first elements and end elements or in case a lateral section should follow between the rear webs, see cross-section drawings for thickness
Material für Metall-Unterkonstruktion	
CD Profile	Dimensions 60/27/06 according to DIN 18182 - Matching cross connectors, multi-connectors and universal connectors
Screws	Drywall screws with TN fine thread
Suspension system	Standard systems, e.g. Nonius suspension or direct suspension with load capacity of 0.4 kN
Material for higher suspension, e.g. with U*psi	
U*psi F-160-profile	As precisely straight, light timber substructure (supplier: Lignotrend)
Suspension system	Commercially available systems, e.g. Nonius suspension or Würth ceiling quick-fixing anchor W-DS.
Material for termination	
Edge battens with rebate	As per detail selected, available from Lignotrend on request
Battens, planed	For fastening onto the element rear side as a stop for the edge batten
Tools	
Immersion saw with rail (circular saw)	For cutting the elements to size.
Jigsaw	For internal corners, round cut-outs.
Hammer drill / rotary hammer	For installation on concrete / masonry.
Cordless screwdriver	With bit holder
Special bit with extended tip	If screwing is done in the joints (supplier: Lignotrend). In case of LIGNO® screws, each screw pack contains a special bit.
Staple gun with special foot	► page 14 loan device available from Lignotrend.
Drill bit tube / Forstner drill, incl. battens in 4, 6 or 8 mm width	For downlights or similar, battens are inserted into the joint for large holes in order to prevent the battens from breaking away.
One-handed ceiling prop(s), Clamp	To temporarily hold the elements while fastening. for firmly pressing on the element when installing the screws.
Chalk line / spirit level / line laser	E.g. for precisely flat installation, for the properly aligned marking of the position of the starting elements on the substructure.
Sanding paper / brush	For touching up fouling and re-application of sanded off UV protection glaze.
Gloves / dust mask	We recommend wearing gloves during installation to avoid contamination.

Tender templates

Detailed texts for invitation to tender on all Lignotrend elements with templates for planning and statics, delivery and installation, trimming and subassembly are available in digital form (in GAEB, RTF or PDF format) from the Internet under ► www.lignotrend.com

Your Lignotrend consultant will provide you with performance specification texts for your individual configuration as needed.

Processing guidelines

The explanations given below must be adhered to without fail.

Please convey the helpful hints also to your customers, developer or follow-up trades!

Incoming goods

Receiving controls

Package undamaged?	Please check it immediately upon receipt and contact Lignotrend in case of any discrepancies. Phone +49 (0) 7755-9200-0.
Delivery scope (panels, accessories) correct?	
Wood moisture content 9 ± 2 %?	



Date / name / signature

Unloading and displacing the packages with a forklift or lifting cart, do not suspend with straps!
Use a crane fork when unloading with a crane.

General information

Lignotrend products, particularly the acoustic panels come with a top-quality visible surface. Hence, it is essential to pay particular attention to having **clean hands** or rather wear **gloves** and do not step on visible surfaces.

Minor longitudinal curvatures of the elements are possible due to minimal differences in wood moisture in the layers and do not represent any deficiency. These curvatures can be compensated by warping against the substructure during installation.

Timber is a natural product and its natural properties, deviations and characteristics therefore always have to be taken into account. In particular, when buying and using it, the purchaser must take into consideration its biologic, physical and chemical properties. The spectrum of natural differences in colour, structure and other qualities within one type of wood is a part of the properties of wood as natural product and does not warrant any complaint or liability claim.



Storage

Carefully **protect** the elements using suitable covering material against: **Moisture** of any kind (rain, fog, splash water, snow), wind as well as **sun** (UV radiation). Store pallets levelled and on clean squared timber. Because of the risk of the formation of condensate beneath the packaging foil: **Storage in dry, closed buildings only!**



Processing

Acclimatisation: Prior to processing, the elements shall be stored in the climate conditions that will prevail in the room later. Bei Failure to comply may, for example, cause gaps to form on the frontal element butt. It is recommended to install elements **not before plastering and floor screed are dried**. Deviant, in case of installation of elements with flame-retardant surface, drying process of plastering and floor screed **must** have terminated!

Please orient yourself by the details described in this documentation during installation. Your Lignotrend technical advisor will be at your disposal for checking an individual, detailed solution in cases where you should have deviating basic conditions in your project.

Appropriate measures to **protect wood surfaces** from marks, stains or damage must always be taken. An important point is the soft padding of the installation props at their top, for example, through a clean piece of carpet. Wearing thin gloves is recommended.

Industrial safety has top priority. Therefore, meet the standard safety precautions with regard to working!

Disposal

Waste released during processing of Lignotrend elements can be disposed of like other waste wood, packaging material (foils/wood) must be disposed of by the processing party according to the local law governing waste.



Cleaning and maintenance

Simple vacuum-cleaning of the visible surface using a brush attachment is absolutely sufficient. If that should prove insufficient, wiping with a damp cloth is possible but **without any detergents!** One should brush and not sand if there is a high dirt accumulation. Take care in case of surfaces that have been treated with a UV protection: Colour differences must be anticipated in this case – contact us.

Expert advice

Do you have any questions about planning, invitation to tender or processing? Do you require a sample piece? Do you need an individual quote? Contact the nearby technical advisor: www.lignotrend.com/consultants